

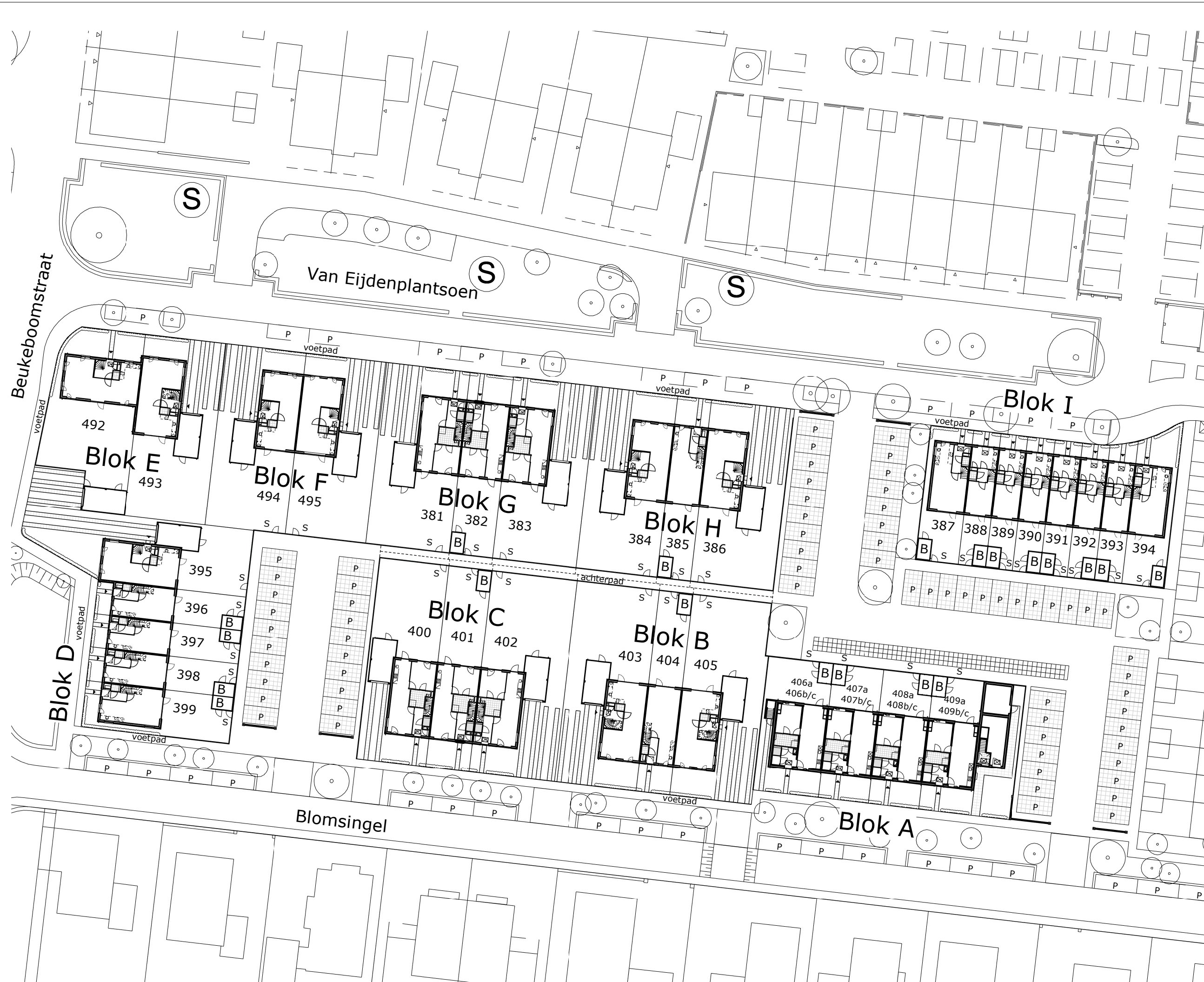









VERKOOPTTEKENINGEN

Bouwnummers 384 t/m 386 en 403 t/m 405

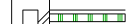



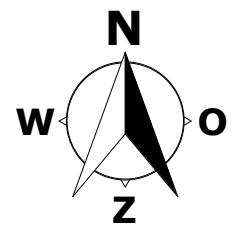











- ### Renvooi
-  entree woning
 -  000 bouwnummer
 -  B houten berging
 -  P parkeervak
 -  tegels, 60x40 cm²
 -  hekwerk met hedera, hoogte 180 cm¹
 -  gemetselde tuinmuur en metselwerk penanten i.c.m. hekwerk met hedera tussen de kolommen, hoogte 180 cm¹
 -  lage haag, hoogte 90 cm¹
 -  S stalen poort





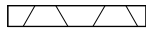



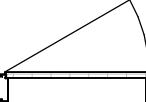
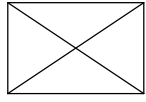
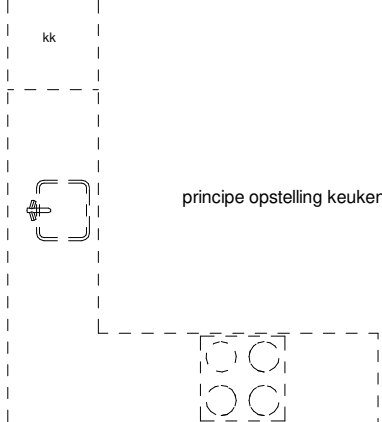























Tekening:	Situatie
Woningtype:	-
Bouwnummer:	-
Bladnummer:	VT-0-S01
Bladformaat:	A3
Schaal:	1:500
Datum:	07-09-2023

De inrichting van de openbare ruimte is indicatief, hier kunnen geen rechten aan worden ontleend.

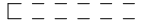
Renvooi bouwkundig

	metselwerk kleur 01 lichtbruin/geel
	staand metselwerk kleur 01a lichtbruin/geel
	metselwerk kleur 02 donkerbruin
	staand metselwerk kleur 02a donkerbruin
	metselwerk kleur 03 wit
	metselwerk kleur 04 oranjebruin
	alternerende gevelbekleding kleur 11 groen/grijs
	dakpannen kleur A zwart
	entree woning
	metselwerk
	alternerende gevelbekleding
	isolatie
	dragende wand
	niet dragende binnenwand
	niet dragende binnenwand (zolder)
	binnendeurkozijn (met bovenlicht)
	kruipluik
	principe opstelling keukenblok

Renvooi installaties

	aansluitpunt licht
	aansluitpunt licht, wand
	centraaldoos met lichtpunt
	armatuur aan de wand
	rookmelder
	aansluitpunt niet bedraad
	beldrukker
	schel
	schakelaar, 1-polig
	werkschakelaar tbv PV-panelen
	schakelaar, WTW
	schakelaar, wissel
	schakelaar, kruis
	schakelaar, serie
	wandcontactdoos 1-voudig met beschermingscontact
	wandcontactdoos 2-voudig met beschermingscontact, verticaal
	wandcontactdoos 2-voudig met beschermingscontact
	thermostaatleiding, bedraad
	wtw mechanische ventilatie-unit incl. warmteterugwinunit
	wp warmtepomp
	inblaasventiel mechanische ventilatie
	uitblaasventiel mechanische ventilatie
	vv verdeler vloerverwarming
	El.rad elektrische radiator
	so stroomomvormer PV-panelen
	kanalen in het zicht
	doucheput
	vloerverwarming
	wm opstelplaats wasmachine
	wd opstelplaats wasdroger
	krijtstreep

Disclaimer

De op deze tekeningen aangegeven maten zijn circa maten in millimeters en tussen de wanden / vloeren gemeten, waarbij geen rekening is gehouden met enige wandafwerking, plinten, aftimmering, ect. In verband met de nauwkeurige uitwerking van details, constructie, maatvoering, materialen e.d. kunnen er kleine afwijkingen ontstaan ten opzichte van de nu vermelde gegevens. Deze geringe afwijkingen geven geen aanleiding tot verrekening. Aan de op deze tekening aangegeven maten kunnen derhalve geen rechten worden ontleend. De op deze tekeningen aangegeven maatvoering is niet geschikt voor opdrachten aan derden door koper(s). De posities van aansluitingen en installatie onderdelen zijn indicatief op tekening aangegeven. De exacte aantallen en posities zullen na berekening in het werk door de installateurs worden bepaald en kunnen afwijken van deze tekening.

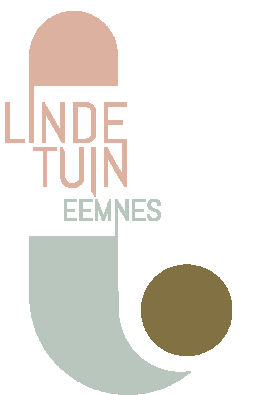

Tekening:	Renvooi
Woningtype:	B48+, E57
Bouwnummer:	384 t/m 386
Bladnummer:	VT-H-00
Bladformaat:	A3
Schaal:	-
Datum:	07-09-2023

Renvooi

- entree woning
- 000 bouwnummer
- B houten berging
- P parkeervak
- tegels, 60x40 cm²
- hekwerk met hедера, hoogte 180 cm¹
- gemetselde tuinmuur en metselwerk penanten i.c.m. hekwerk met hедера tussen de kolommen, hoogte 180 cm¹
- lage haag, hoogte 90 cm¹
- S stalen poort

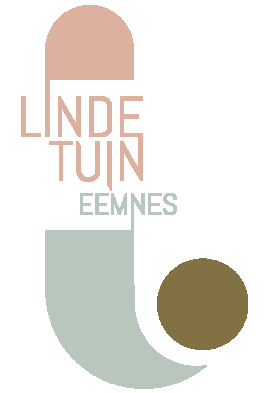
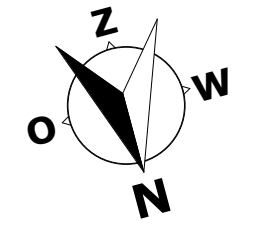
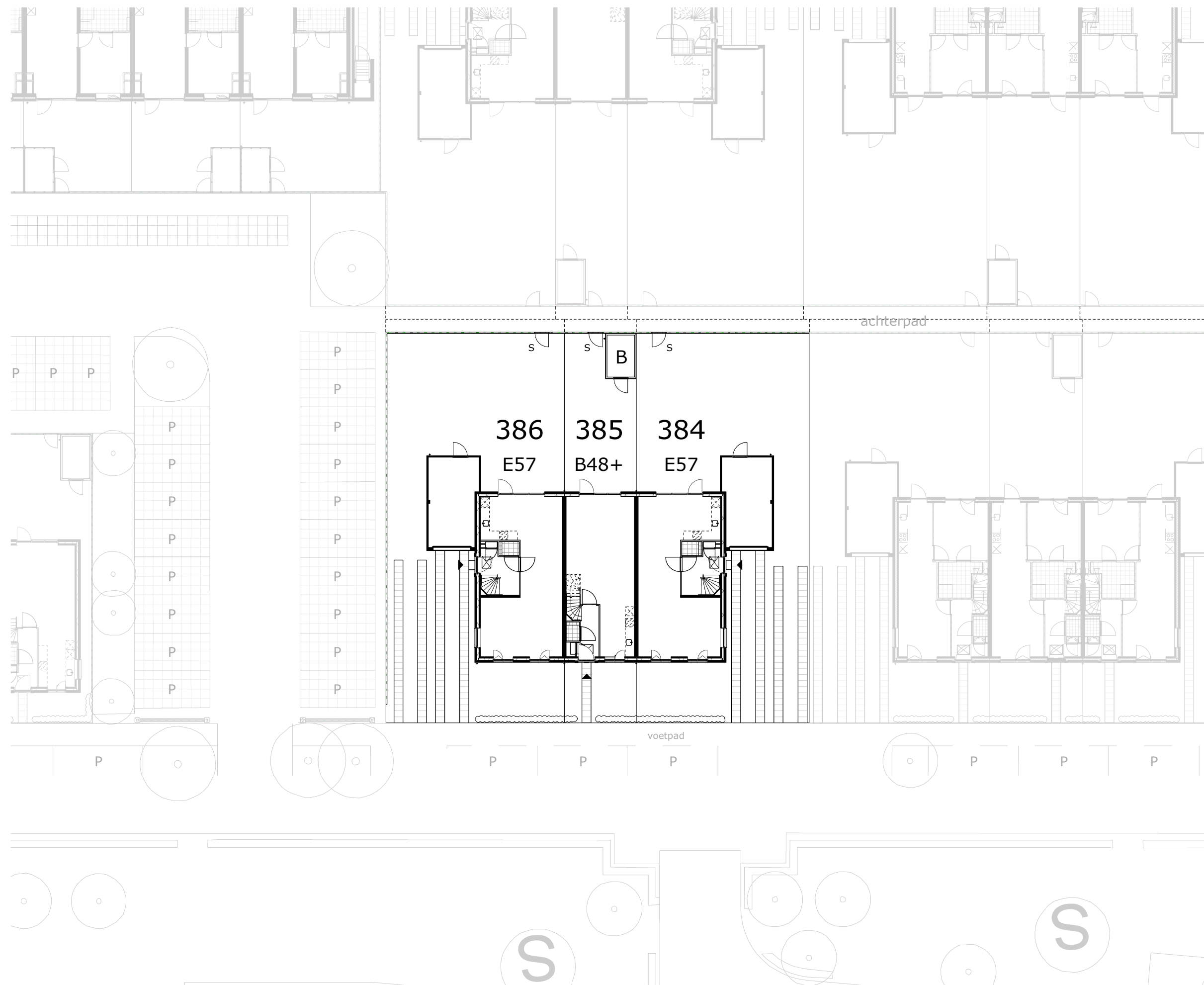

Tekening: **Situatie blok H**

Woningtype: **B48+, E57**

Bouwnummer: **384 t/m 386**

Bladnummer: **VT-0-S0H**

Bladformaat: **A3**

Schaal: **1:250**

Datum: **07-09-2023**

De inrichting van de openbare ruimte is indicatief, hier kunnen geen rechten aan worden ontleend.



Voorgevel

Bwnr. 386

Bwnr. 385

Bwnr. 384

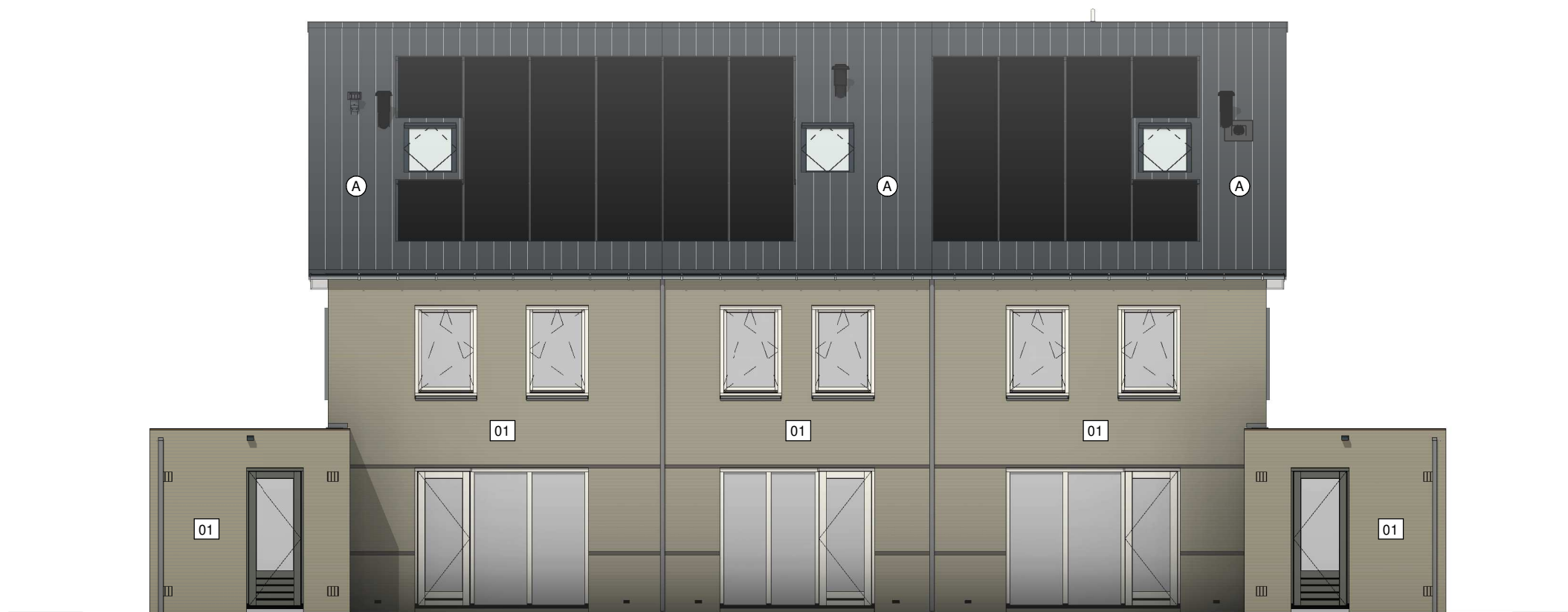

Achtergevel

Bwnr. 384

Bwnr. 385

Bwnr. 386

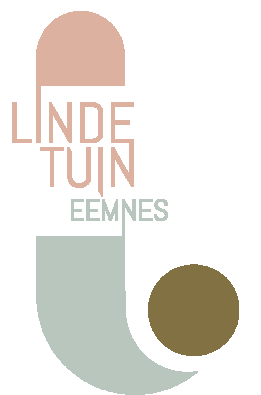

Tekening: Gevels

Woningtype: B48+, E57

Bouwnummer: 384 t/m 386

Bladnummer: VT-H-00a

Bladformaat: A3

Schaal: 1:100

Datum: 07-09-2023



Linker zijgevel

Bwnr. 386



Rechter zijgevel

Bwnr. 384

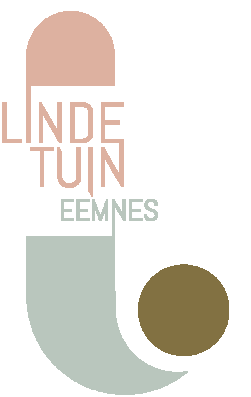

Tekening: Zijgevels

Woningtype: B48+, E57

Bouwnummer: 384 t/m 386

Bladnummer: VT-H-00b

Bladformaat: A3

Schaal: 1:100

Datum: 07-09-2023

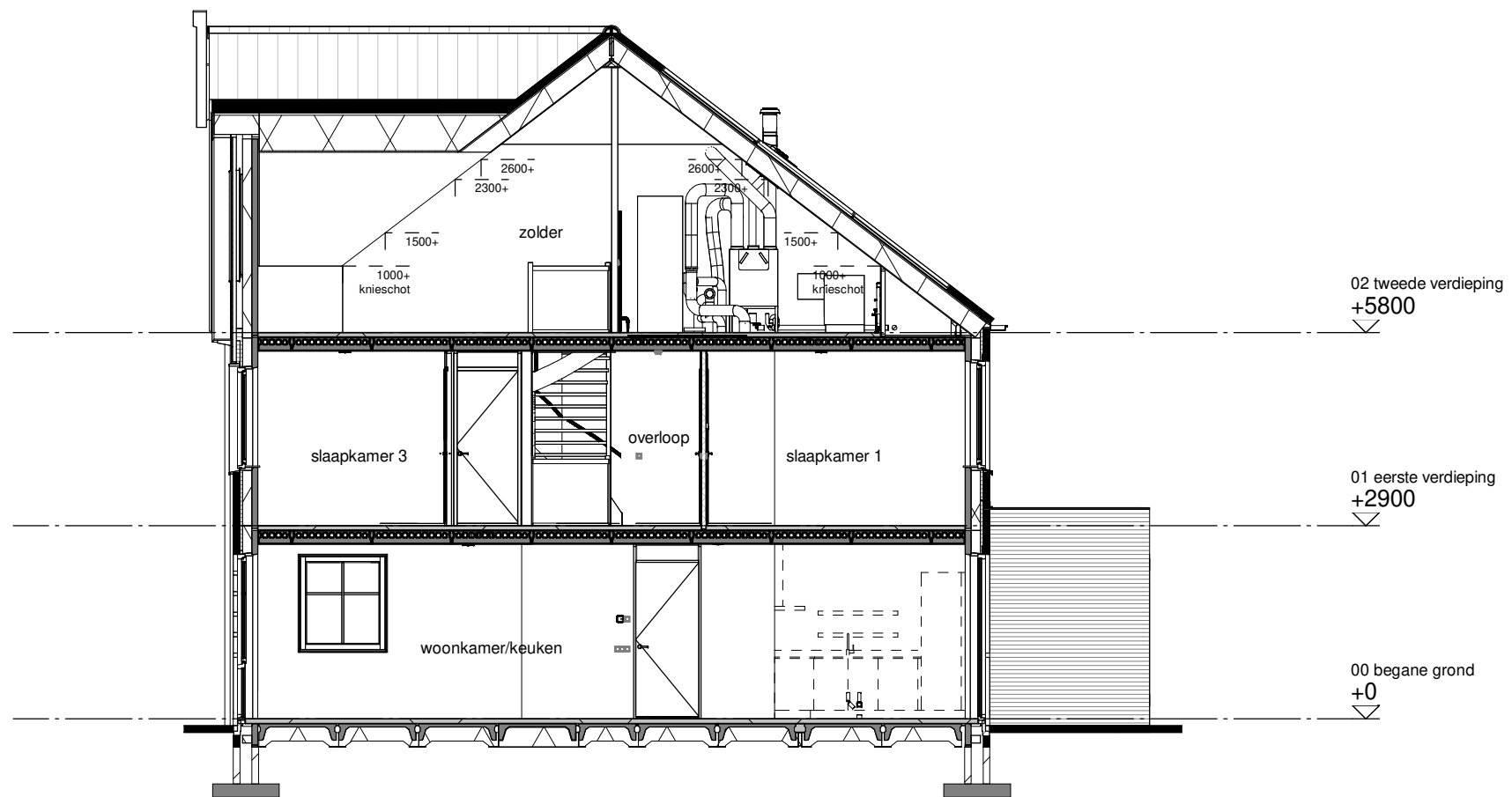

Bwnr. 386

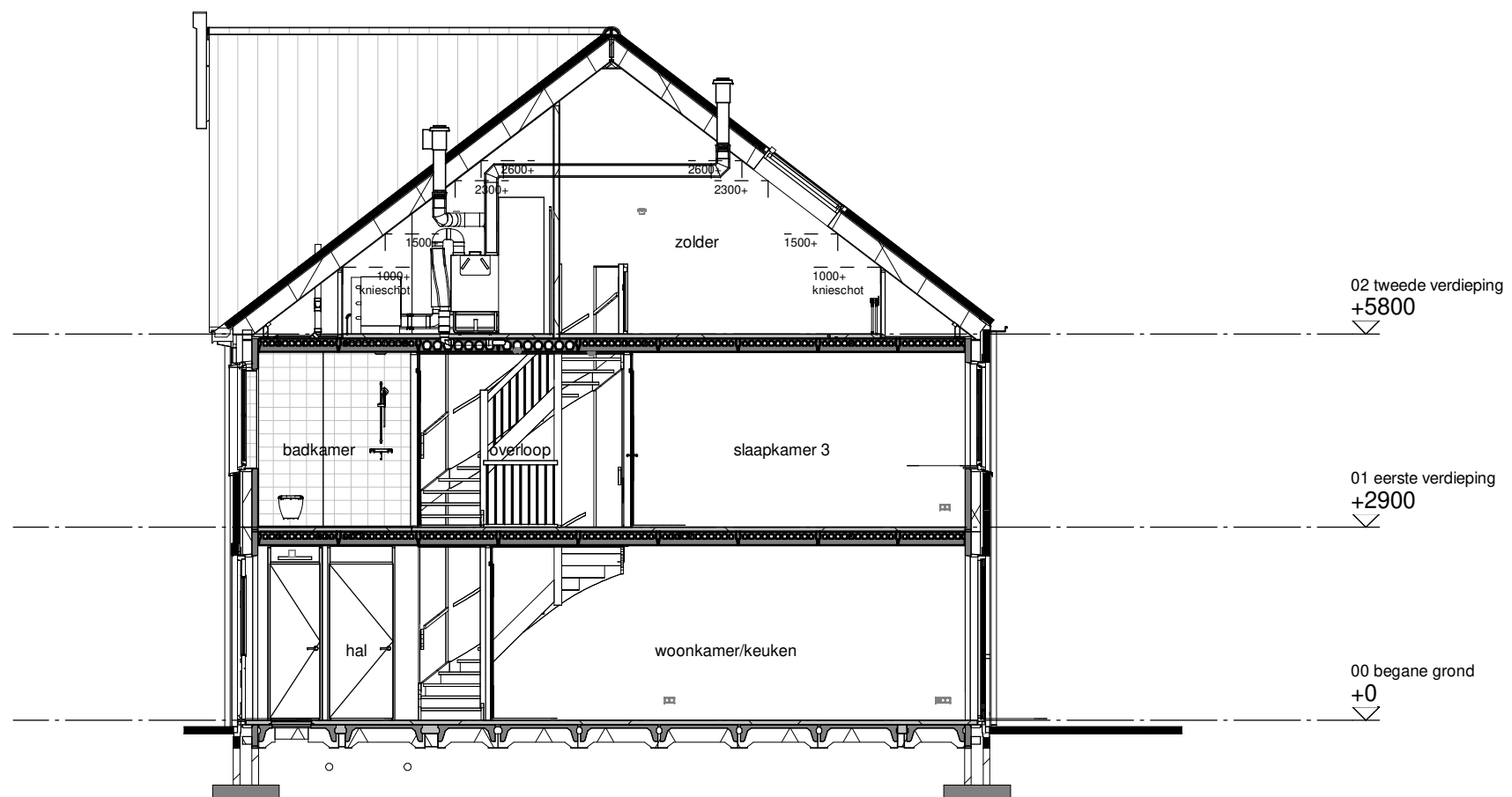

Bwnr. 385

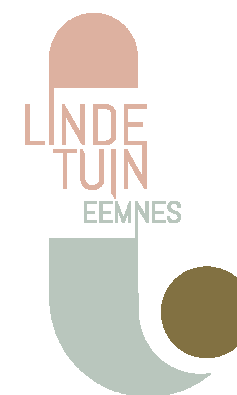

Tekening: Doorsneden

Woningtype: B48+, E57

Bouwnummer: 384 t/m 386

Bladnummer: VT-H-00c

Bladformaat: A3

Schaal: 1:100

Datum: 07-09-2023

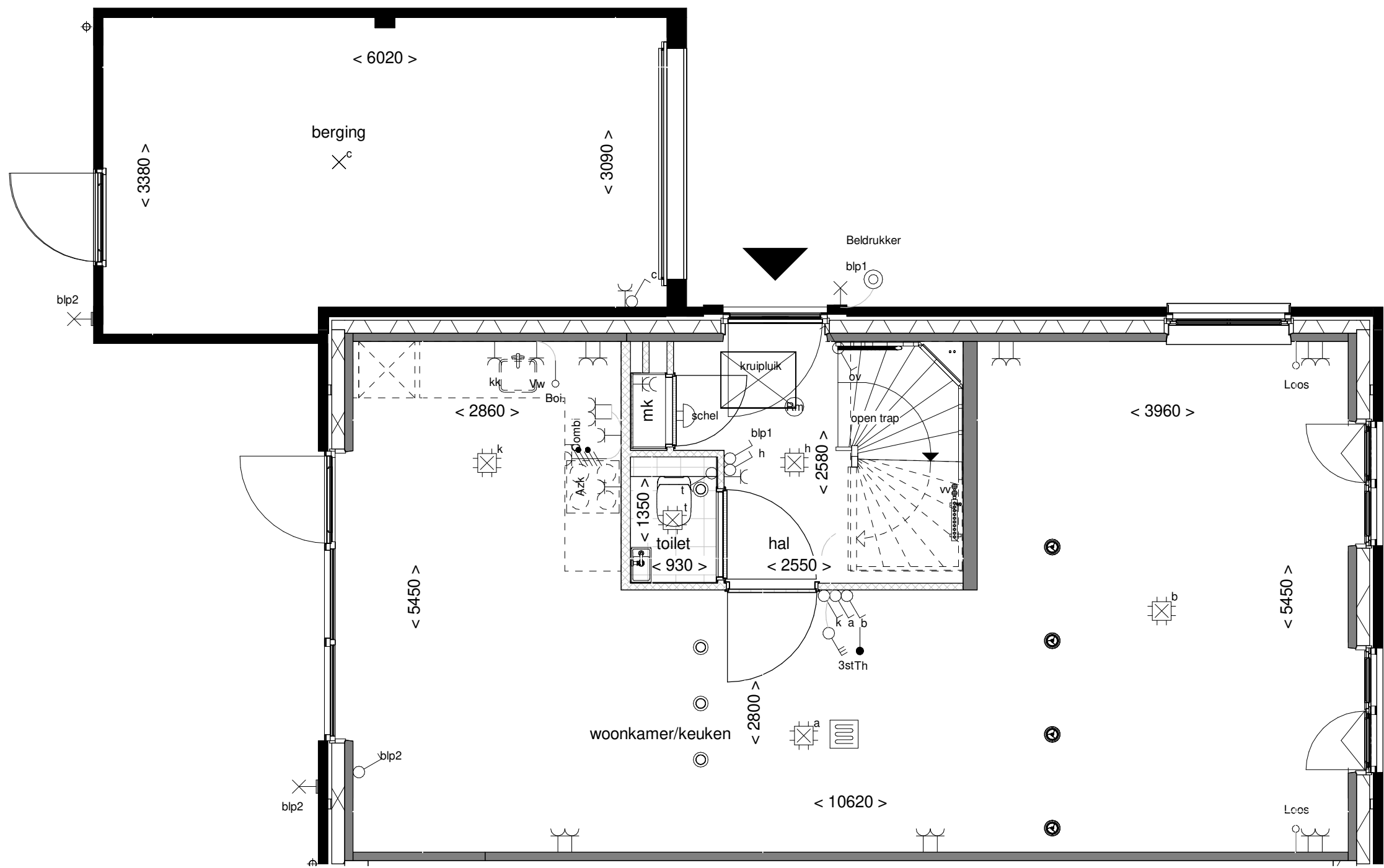

Tekening: Begane grond

Woningtype: E57

Bouwnummer: 384

Bladnummer: VT-E57-384a

Bladformaat: A3

Schaal: 1:50

Datum: 07-09-2023

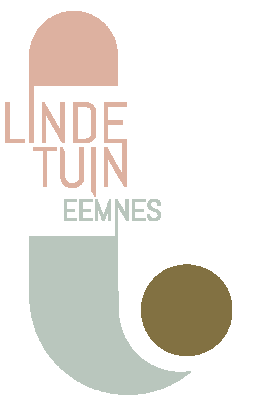
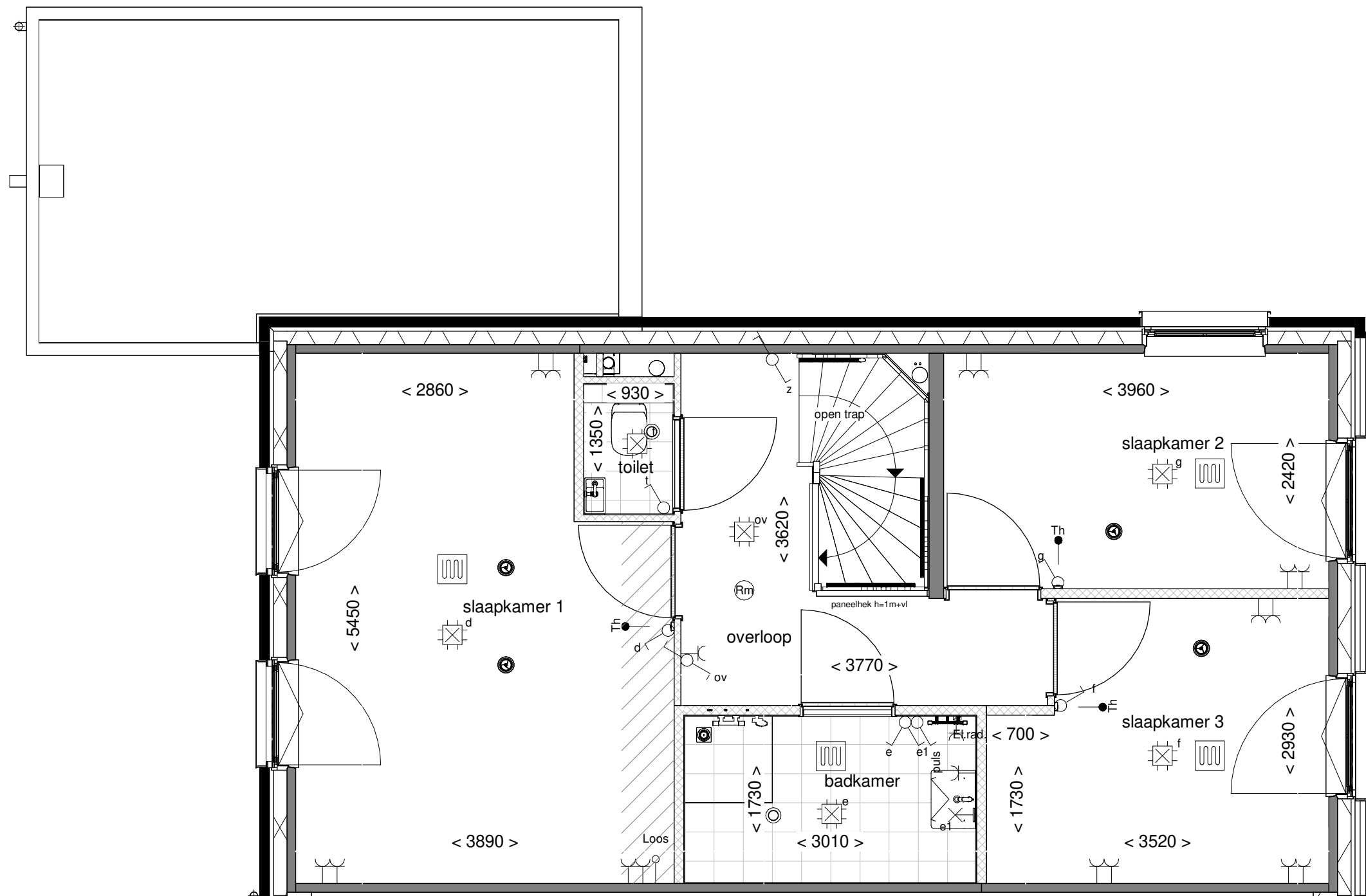

Tekening: 1e Verdieping

Woningtype: E57

Bouwnummer: 384

Bladnummer: VT-E57-384b

Bladformaat: A3

Schaal: 1:50

Datum: 07-09-2023

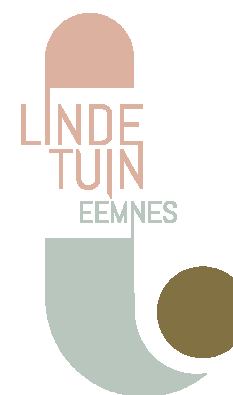
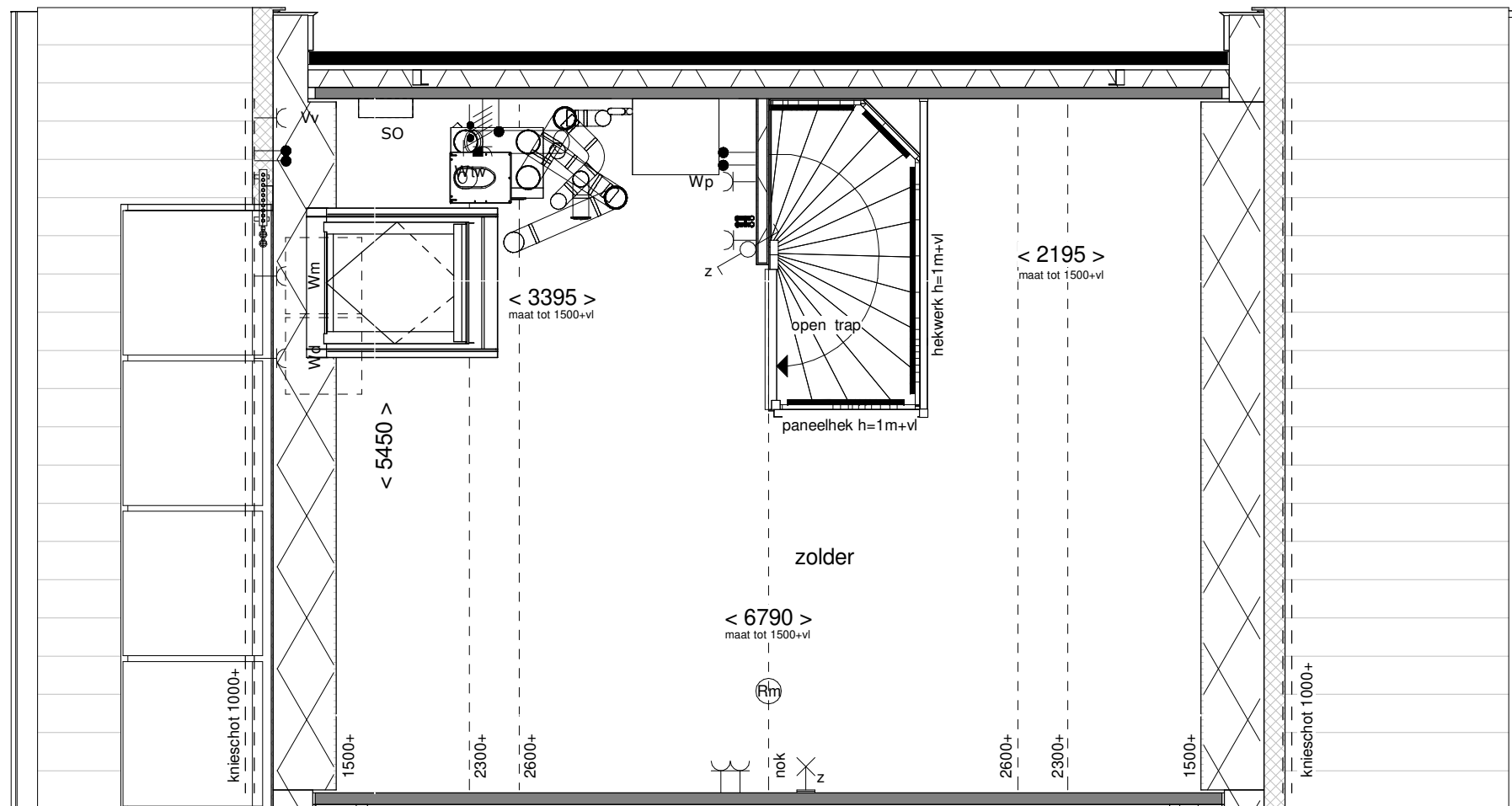

Tekening: 2e Verdieping

Woningtype: E57

Bouwnummer: 384

Bladnummer: VT-E57-384c

Bladformaat: A3

Schaal: 1:50

Datum: 07-09-2023

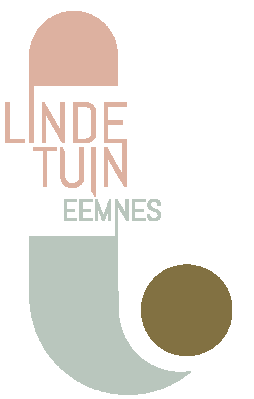
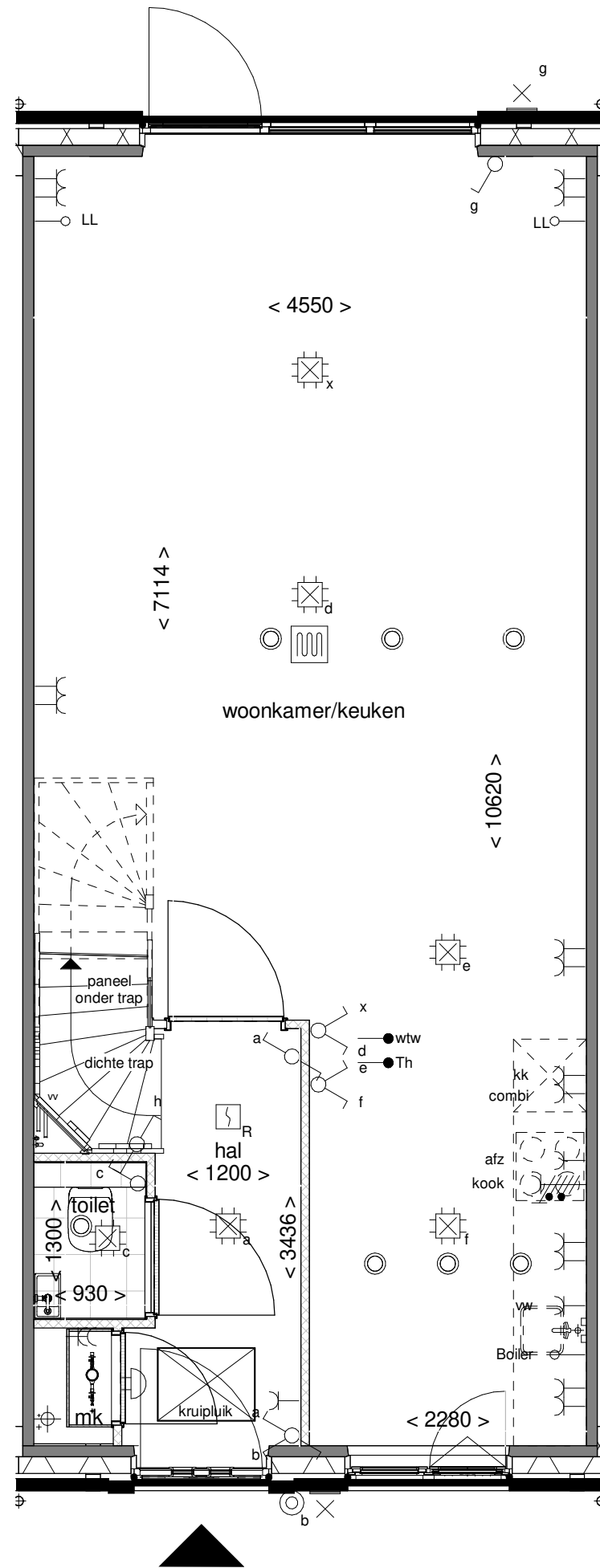

Tekening: **Begane grond**

Woningtype: **B48+**

Bouwnummer: **385**

Bladnummer: **VT-B48+-385a**

Bladformaat: **A3**

Schaal: **1:50**

Datum: **07-09-2023**

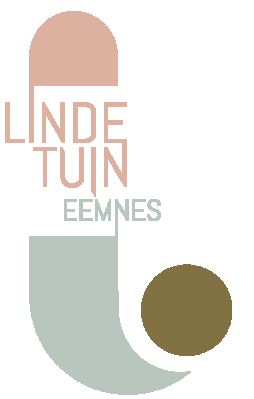
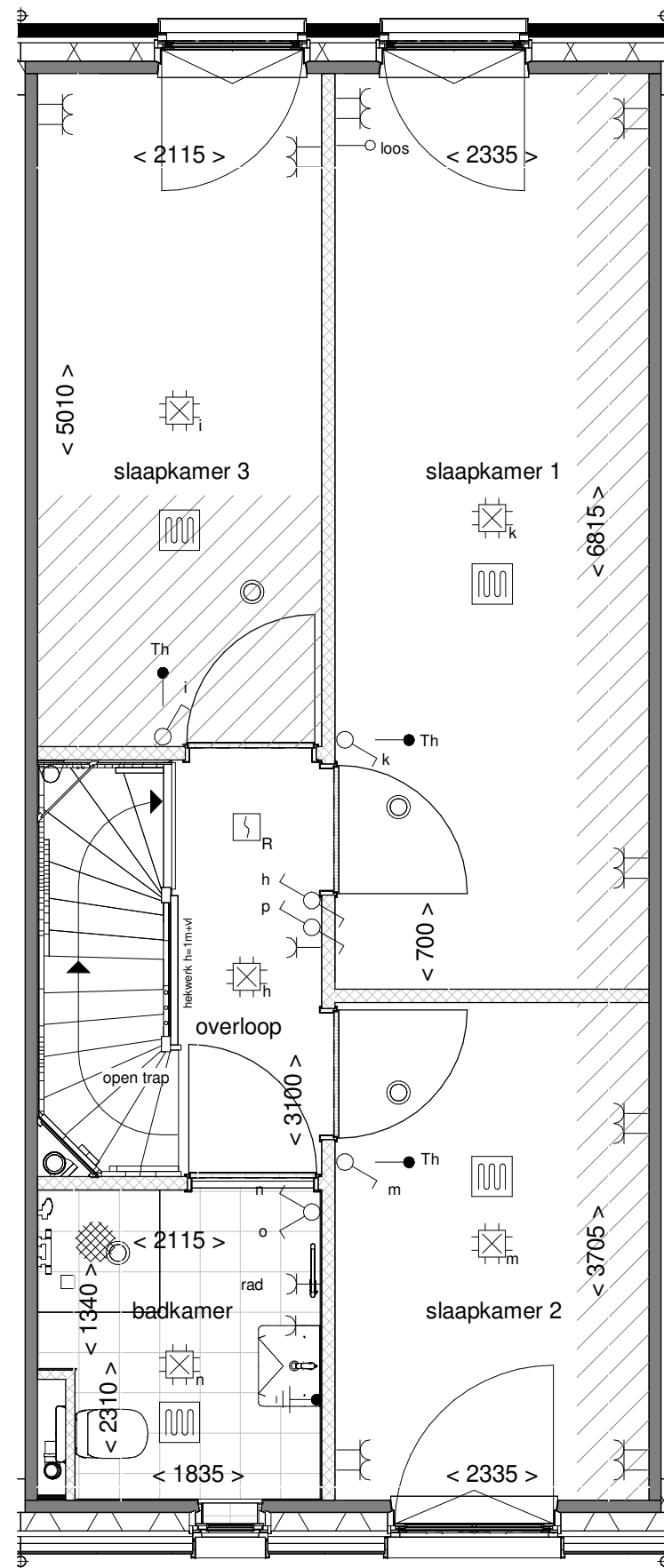

Tekening: 1e Verdieping

Woningtype: B48+

Bouwnummer: 385

Bladnummer: VT-B48+-385b

Bladformaat: A3

Schaal: 1:50

Datum: 07-09-2023

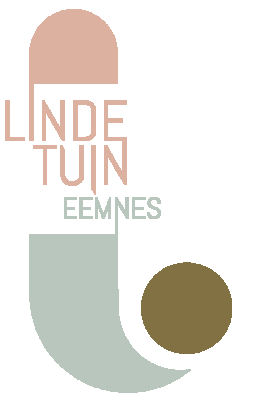
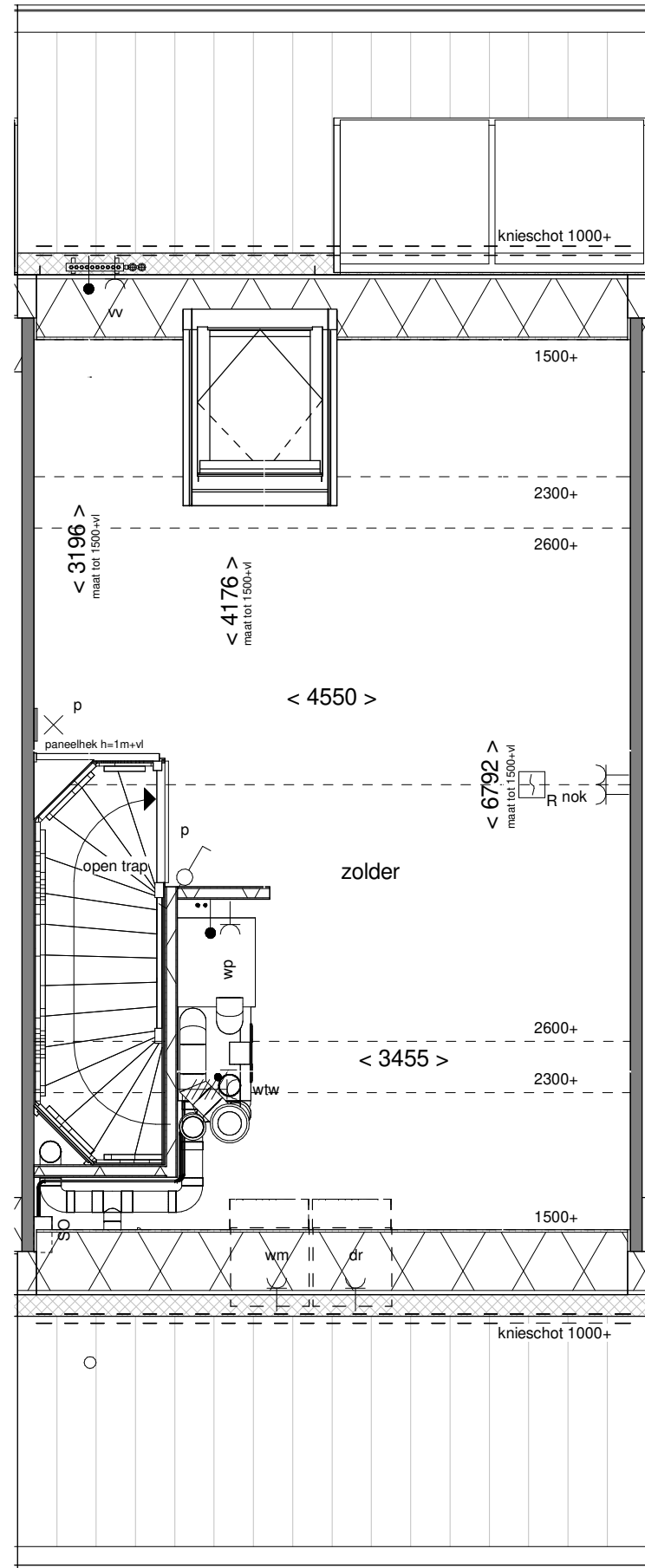

Tekening: 2e Verdieping

Woningtype: B48+

Bouwnummer: 385

Bladnummer: VT-B48+-385c

Bladformaat: A3

Schaal: 1:50

Datum: 07-09-2023

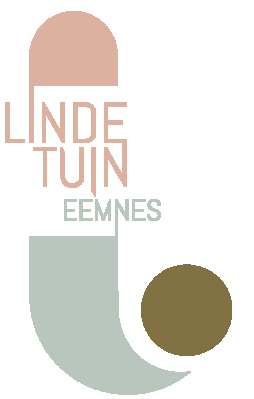
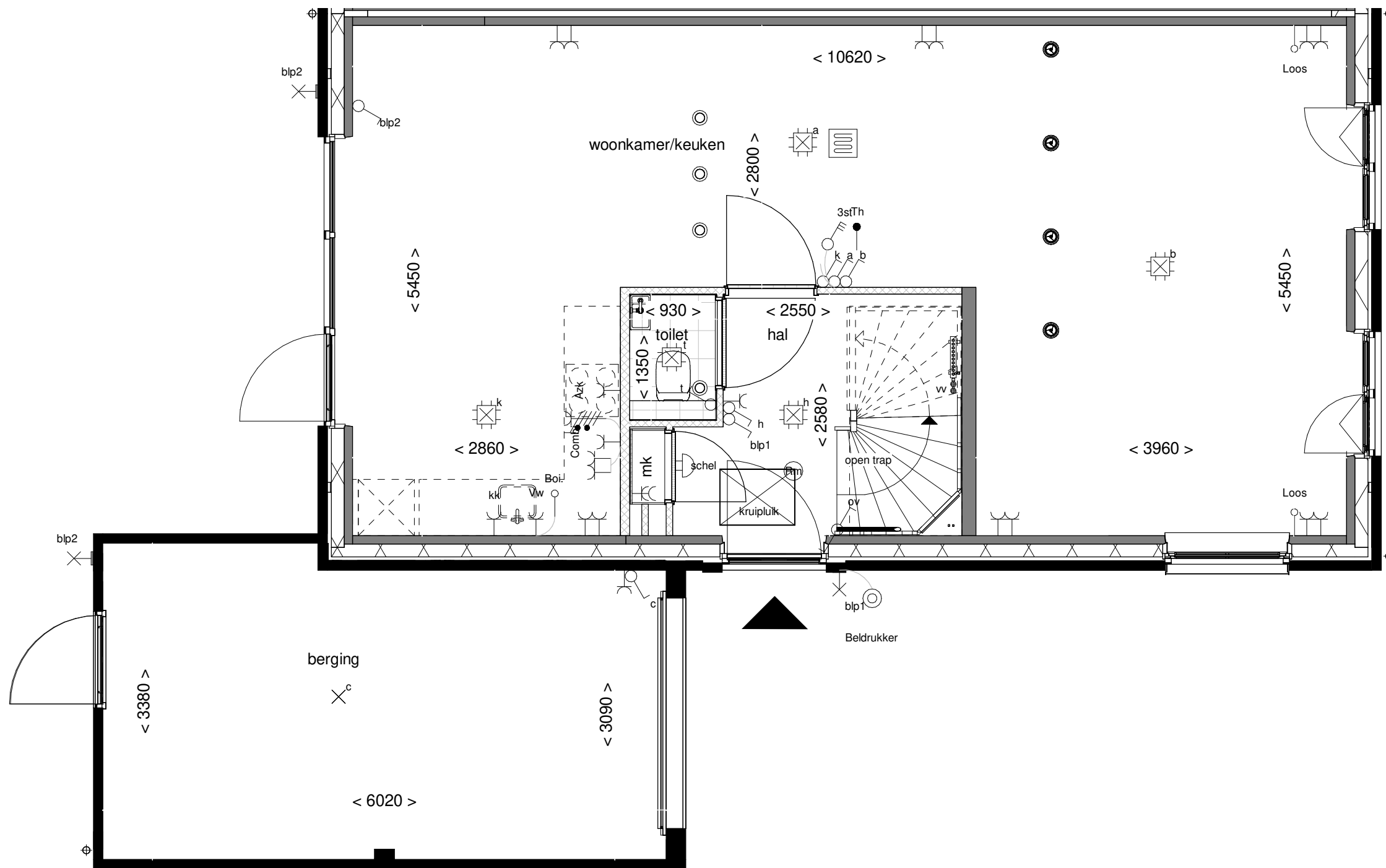

Tekening: **Begane grond**

Woningtype: **E57**

Bouwnummer: **386**

Bladnummer: **VT-E57-386a**

Bladformaat: **A3**

Schaal: **1:50**

Datum: **07-09-2023**

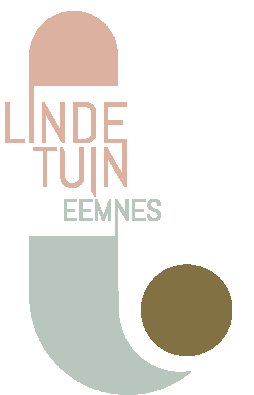
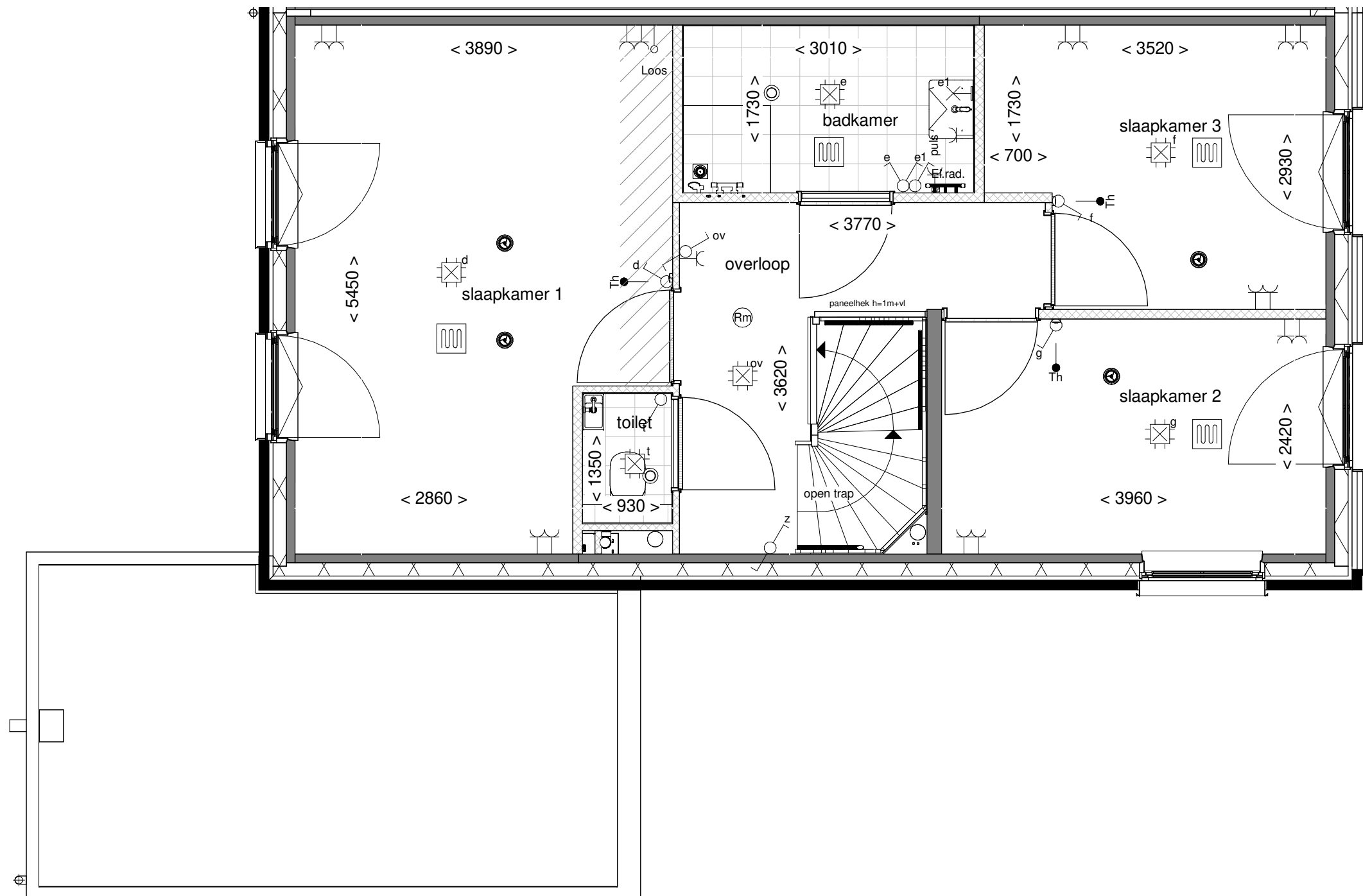

Tekening: 1e Verdieping

Woningtype: E57

Bouwnummer: 386

Bladnummer: VT-E57-386b

Bladformaat: A3

Schaal: 1:50

Datum: 07-09-2023

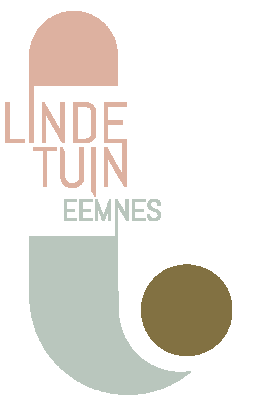
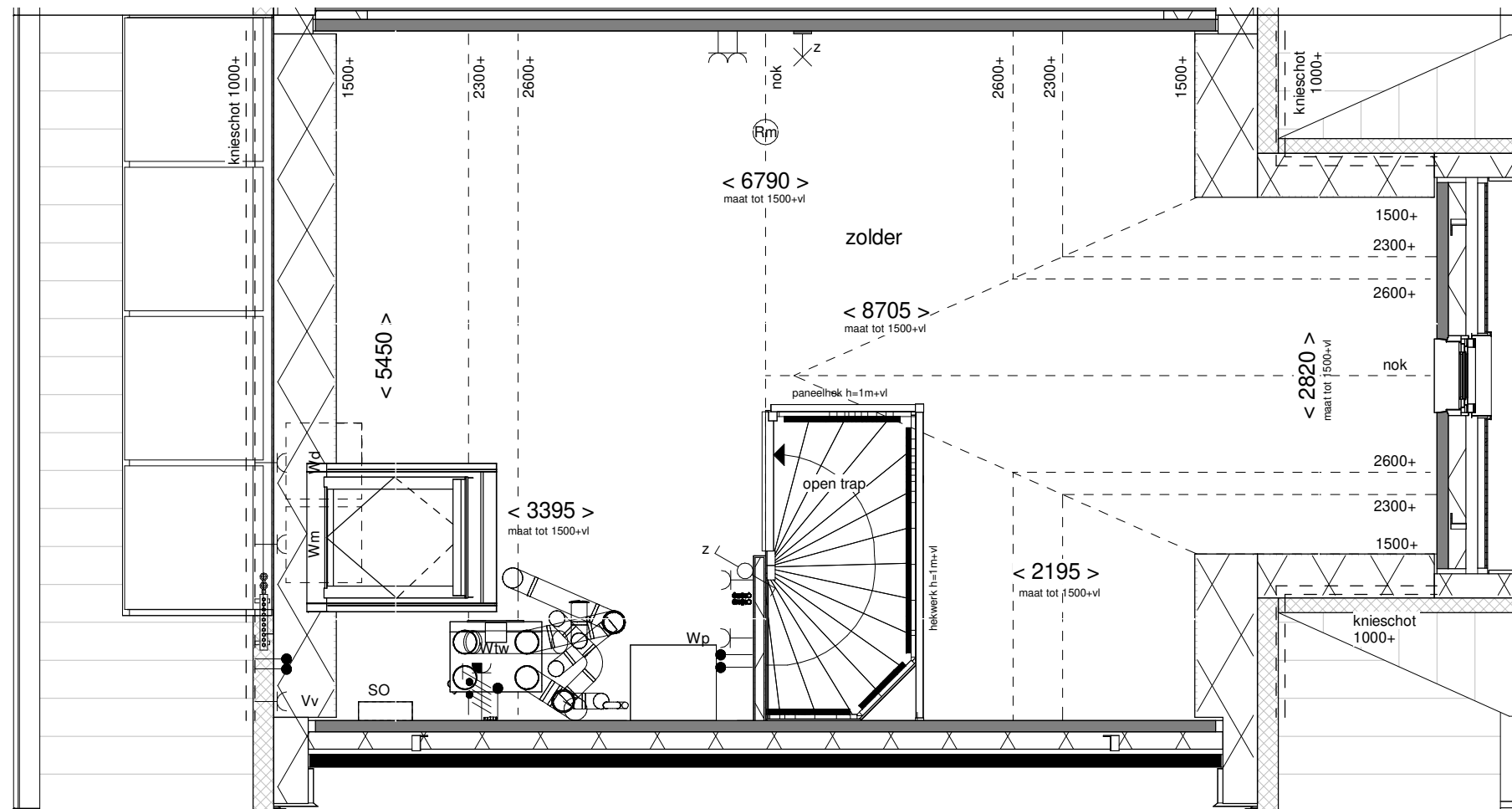

Tekening: 2e Verdieping

Woningtype: E57

Bouwnummer: 386

Bladnummer: VT-E57-386c

Bladformaat: A3

Schaal: 1:50

Datum: 07-09-2023

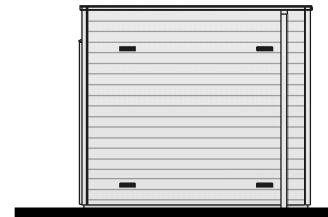

Voorgevel

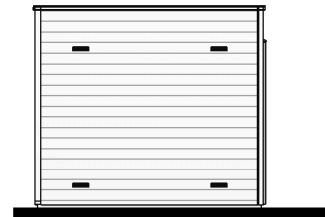

Achtergevel

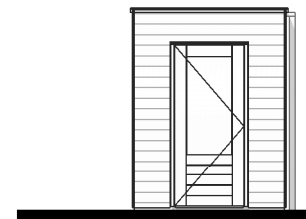

Linker zijgevel

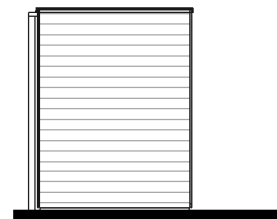

Rechter zijgevel

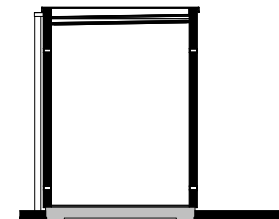

Doorsnede A

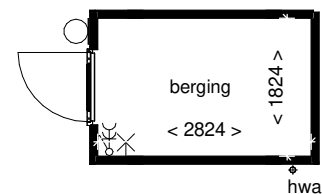

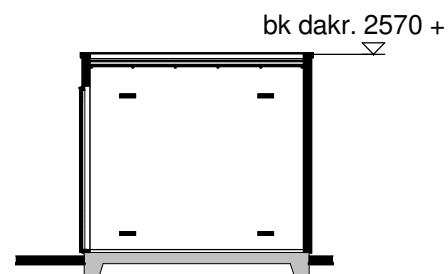

Begane grond







Doorsnede B

Renvooi

-  houten rabatdelen
-  houten wanden

Installaties

-  - enkelpolige schakelaar
-  - dubbele wandcontactdoos
-  - lichtpunt buiten
-  - lichtpunt aan wand

Disclaimer

De op deze tekening aangegeven maten zijn circa maten in millimeters en tussen de wanden / vloeren gemeten, waarbij geen rekening is gehouden met enige wandafwerking, plinten, aftimmering, ect. In verband met de nauwkeurige uitwerking van details, constructie, maatvoering, materialen e.d. kunnen er kleine afwijkingen ontstaan ten opzichte van de nu vermelde gegevens. Deze geringe afwijkingen geven geen aanleiding tot verrekening. Aan de op deze tekening aangegeven maten kunnen derhalve geen rechten worden ontleend. De op deze tekening aangegeven maatvoering is niet geschikt voor opdrachten aan derden door koper(s). De posities van aansluitingen en installatie onderdelen zijn indicatief op tekening aangegeven. De exacte aantallen en posities zullen na berekening in het werk door de installateurs worden bepaald en kunnen afwijken van deze tekening.

3D Impressie

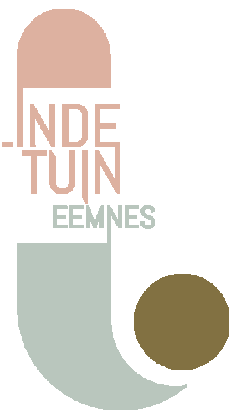
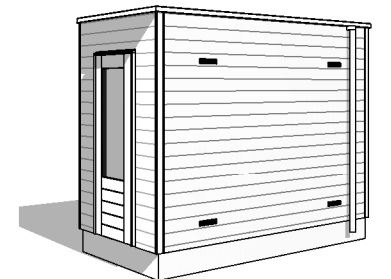

Tekening: **Berging enkel**

Woningtype: -

Bouwnummer: -

Bladnummer: VT-00-B1

Bladformaat: A3















Schaal: 1:100

Datum: 07-09-2023







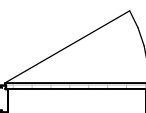
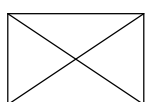
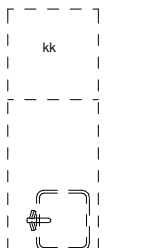
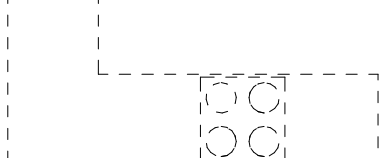























Van toepassing bij bouwnummer: 394

Gespiegeld bij bouwnummer: 382, 385, 387, 401 en 404

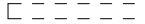
Renvooi bouwkundig

	metselwerk kleur 01 lichtbruin/geel
	staand metselwerk kleur 01a lichtbruin/geel
	metselwerk kleur 02 donkerbruin
	staand metselwerk kleur 02a donkerbruin
	metselwerk kleur 03 wit
	metselwerk kleur 04 oranjebruin
	alternerende gevelbekleding kleur 11 groen/grijs
	dakpannen kleur A zwart
	entree woning
	metselwerk
	alternerende gevelbekleding
	isolatie
	dragende wand
	niet dragende binnenwand
	niet dragende binnenwand (zolder)
	binnendeurkozijn (met bovenlicht)
	kruipluik
	principe opstelling keukenblok
	

Renvooi installaties

	aansluitpunt licht
	aansluitpunt licht, wand
	centraaldoos met lichtpunt
	armatuur aan de wand
	rookmelder
	aansluitpunt niet bedraad
	beldrukker
	schel
	schakelaar, 1-polig
	werkschakelaar tbv PV-panelen
	schakelaar, WTW
	schakelaar, wissel
	schakelaar, kruis
	schakelaar, serie
	wandcontactdoos 1-voudig met beschermingscontact
	wandcontactdoos 2-voudig met beschermingscontact, verticaal
	wandcontactdoos 2-voudig met beschermingscontact
	thermostaatleiding, bedraad
	mechanische ventilatie-unit incl. warmteterugwinunit
	warmtepomp
	inblaasventiel mechanische ventilatie
	uitblaasventiel mechanische ventilatie
	verdelers vloerverwarming
	elektrische radiator
	stroomomvormer PV-panelen
	kanalen in het zicht
	doucheput
	vloerverwarming
	opstelplaats wasmachine
	opstelplaats wasdroger
	krijtstreep

Disclaimer

De op deze tekeningen aangegeven maten zijn circa maten in millimeters en tussen de wanden / vloeren gemeten, waarbij geen rekening is gehouden met enige wandafwerking, plinten, aftimmering, ect. In verband met de nauwkeurige uitwerking van details, constructie, maatvoering, materialen e.d. kunnen er kleine afwijkingen ontstaan ten opzichte van de nu vermelde gegevens. Deze geringe afwijkingen geven geen aanleiding tot verrekening. Aan de op deze tekening aangegeven maten kunnen derhalve geen rechten worden ontleend. De op deze tekeningen aangegeven maatvoering is niet geschikt voor opdrachten aan derden door koper(s). De posities van aansluitingen en installatie onderdelen zijn indicatief op tekening aangegeven. De exacte aantallen en posities zullen na berekening in het werk door de installateurs worden bepaald en kunnen afwijken van deze tekening.

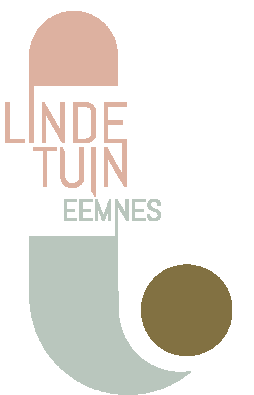

Tekening:	Renvooi
Woningtype:	B48+, E57
Bouwnummer:	403 t/m 405
Bladnummer:	VT-B-00
Bladformaat:	A3
Schaal:	-
Datum:	07-09-2023

Renvooi

- entree woning
- 000 bouwnummer
- B houten berging
- P parkeervak
- tegels, 60x40 cm²
- hekwerk met hedera, hoogte 180 cm¹
- gemetselde tuinmuur en metselwerk penanten i.c.m. hekwerk met hedera tussen de kolommen, hoogte 180 cm¹
- lage haag, hoogte 90 cm¹
- S stalen poort

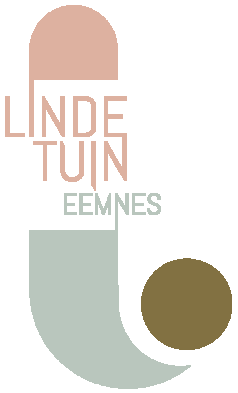
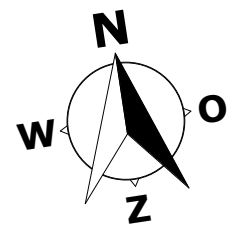
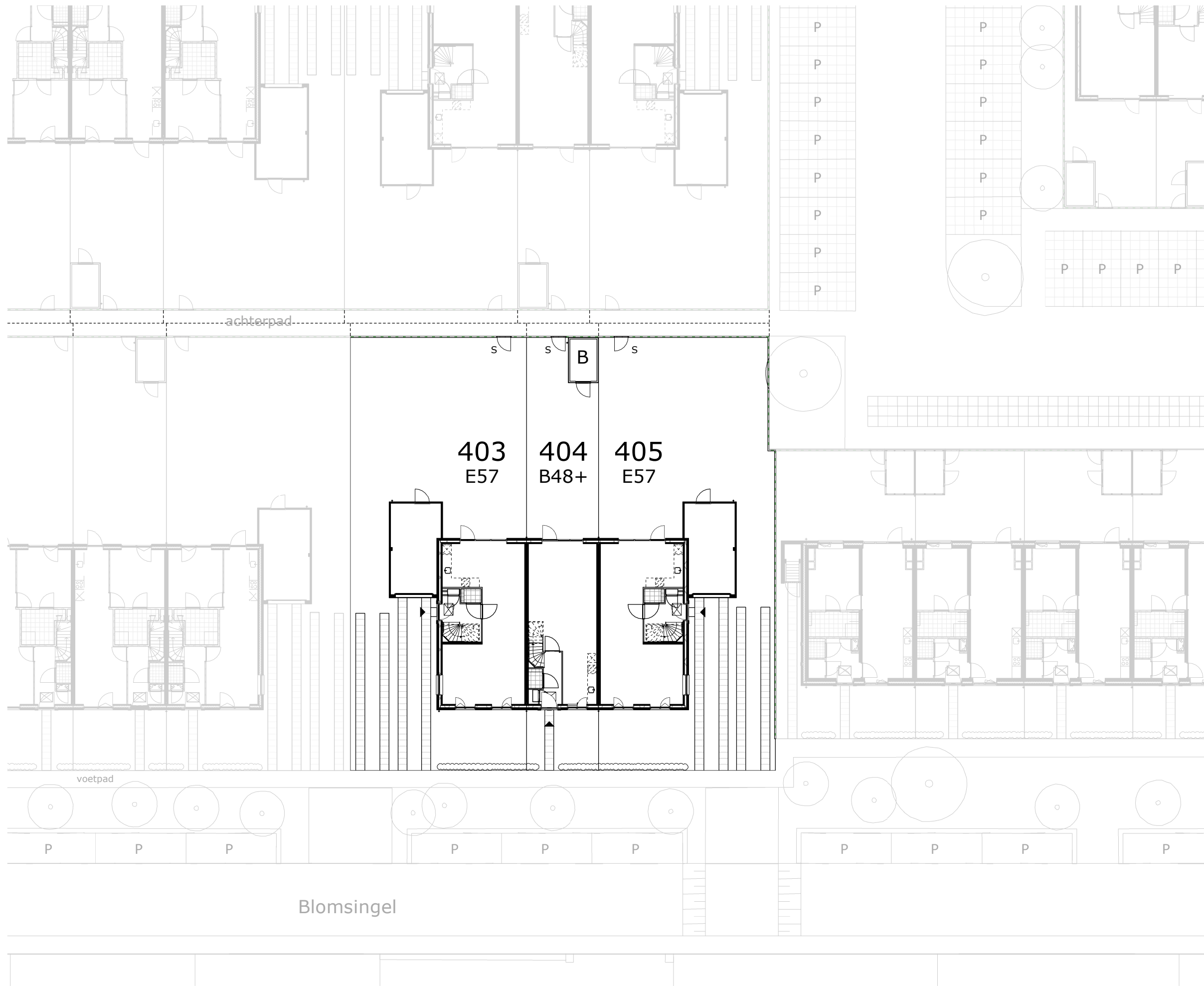

Tekening: **Situatie blok B**

Woningtype: **B48+, E57**

Bouwnummer: **403 t/m 405**

Bladnummer: **VT-0-S0B**

Bladformaat: **A3**

Schaal: **1:250**

Datum: **07-09-2023**

De inrichting van de openbare ruimte is indicatief, hier kunnen geen rechten aan worden ontleend.



Voorgevel

Bwnr. 403

Bwnr. 404

Bwnr. 405

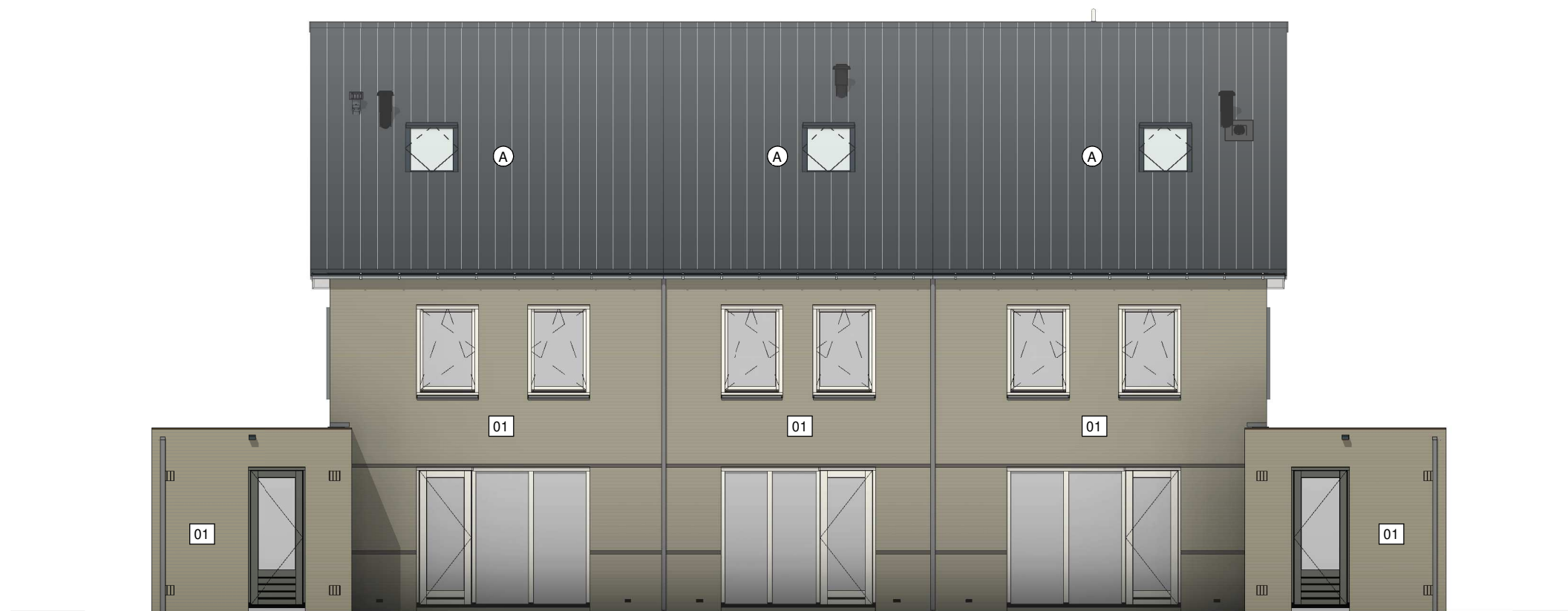

Achtergevel

Bwnr. 405

Bwnr. 404

Bwnr. 403

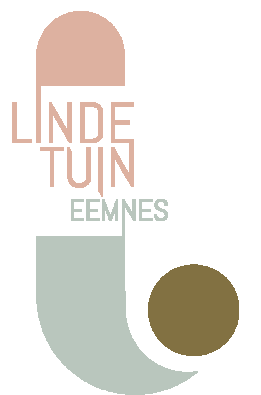

Tekening: Gevels

Woningtype: E57, B48+

Bouwnummer: 403 t/m 405

Bladnummer: VT-B-00a

Bladformaat: A3

Schaal: 1:100

Datum: 07-09-2023



Linker zijgevel

Bwnr. 403



Rechter zijgevel

Bwnr. 405

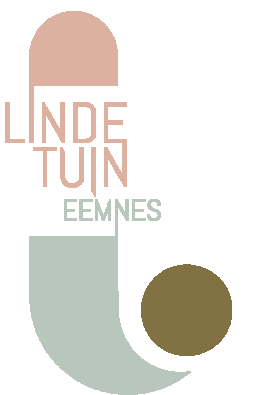

Tekening: Zijgevels

Woningtype: E57, B48+

Bouwnummer: 403 t/m 405

Bladnummer: VT-B-00b

Bladformaat: A3

Schaal: 1:100

Datum: 07-09-2023

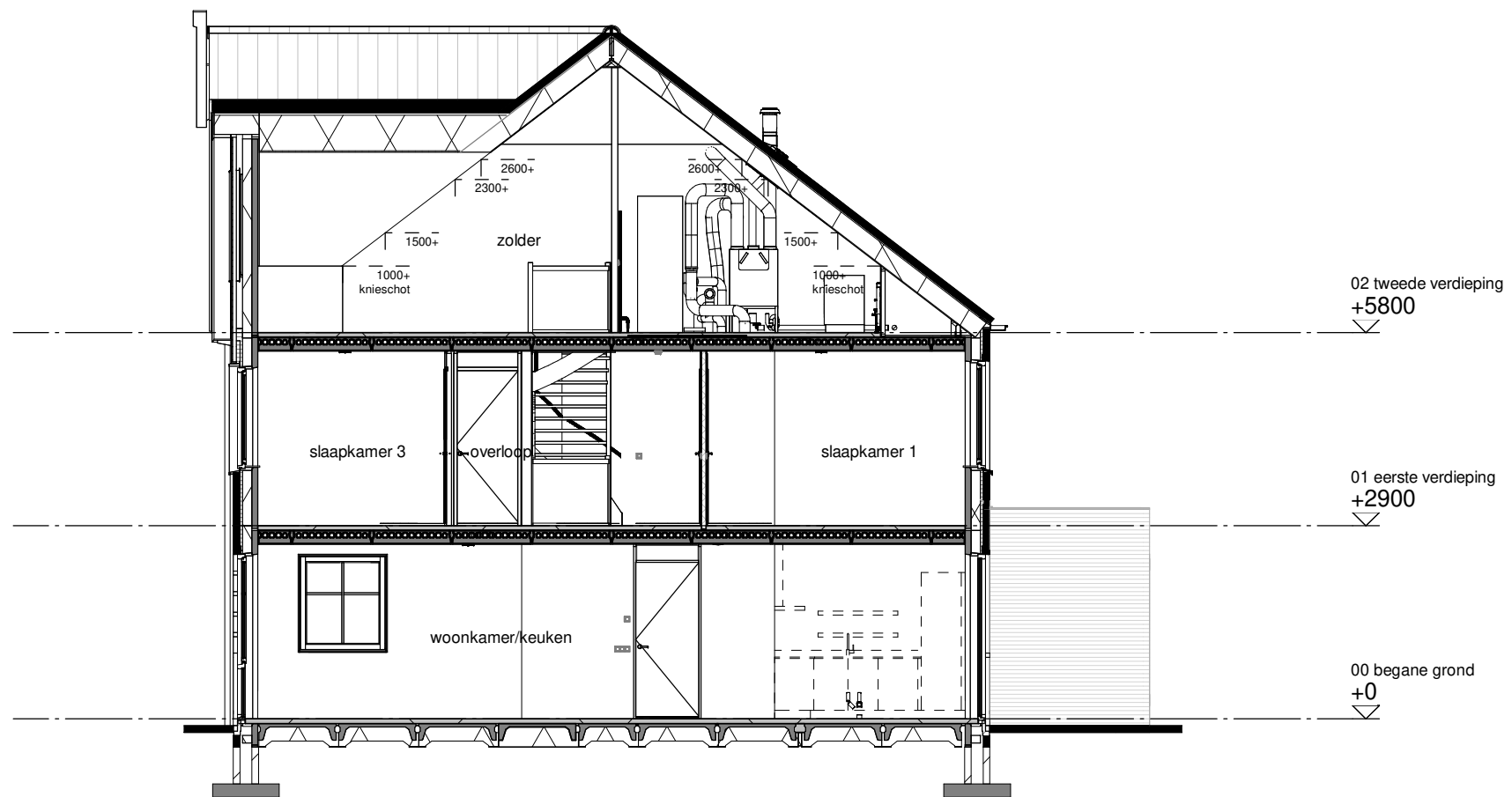

Bwnr. 403

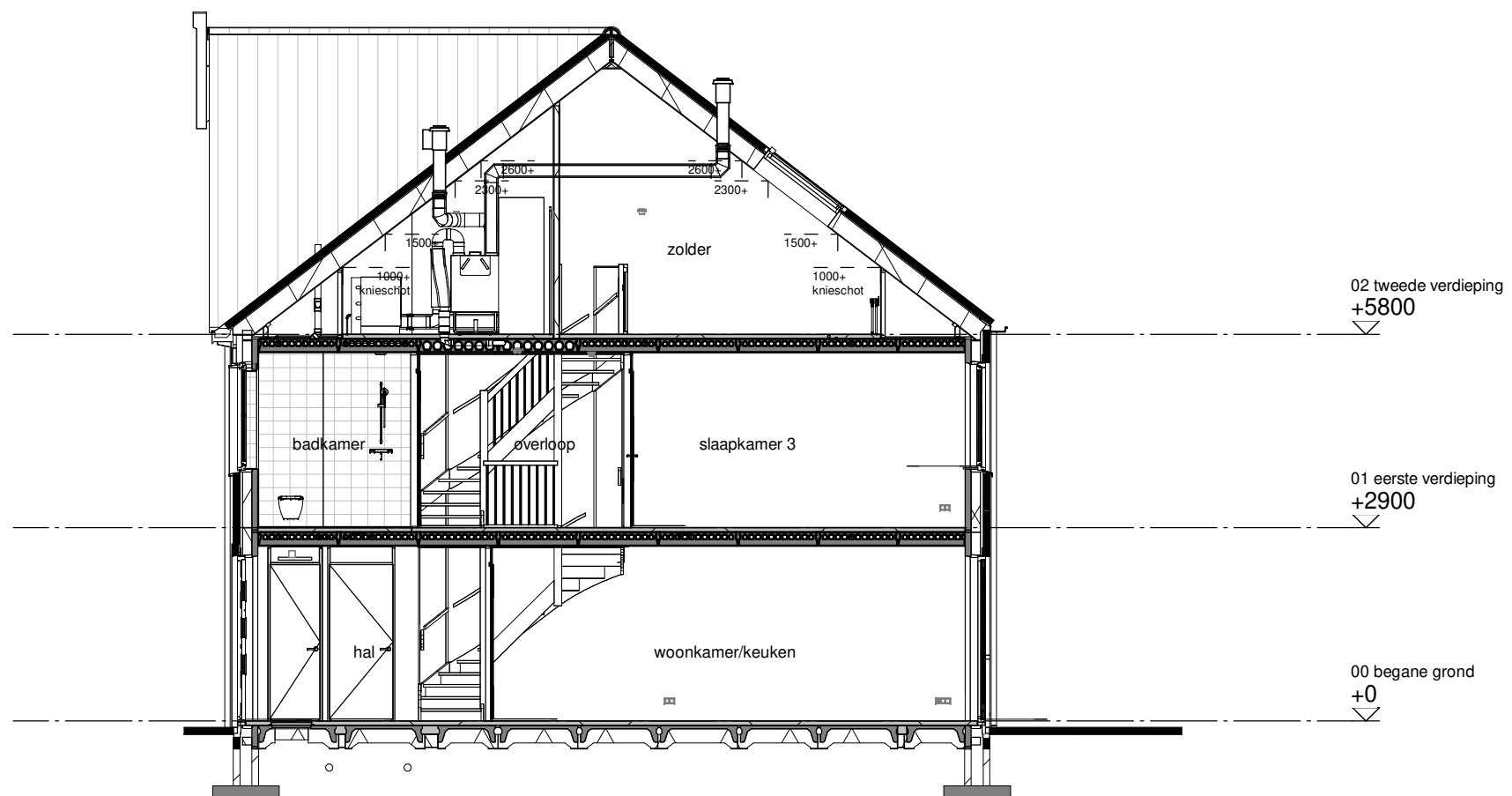

Bwnr. 404



Tekening: Doorsneden

Woningtype: E57, B48+

Bouwnummer: 403 t/m 405

Bladnummer: VT-B-00c

Bladformaat: A3

Schaal: 1:100

Datum: 07-09-2023

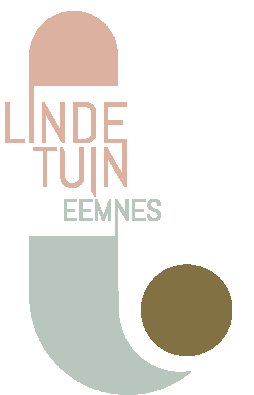
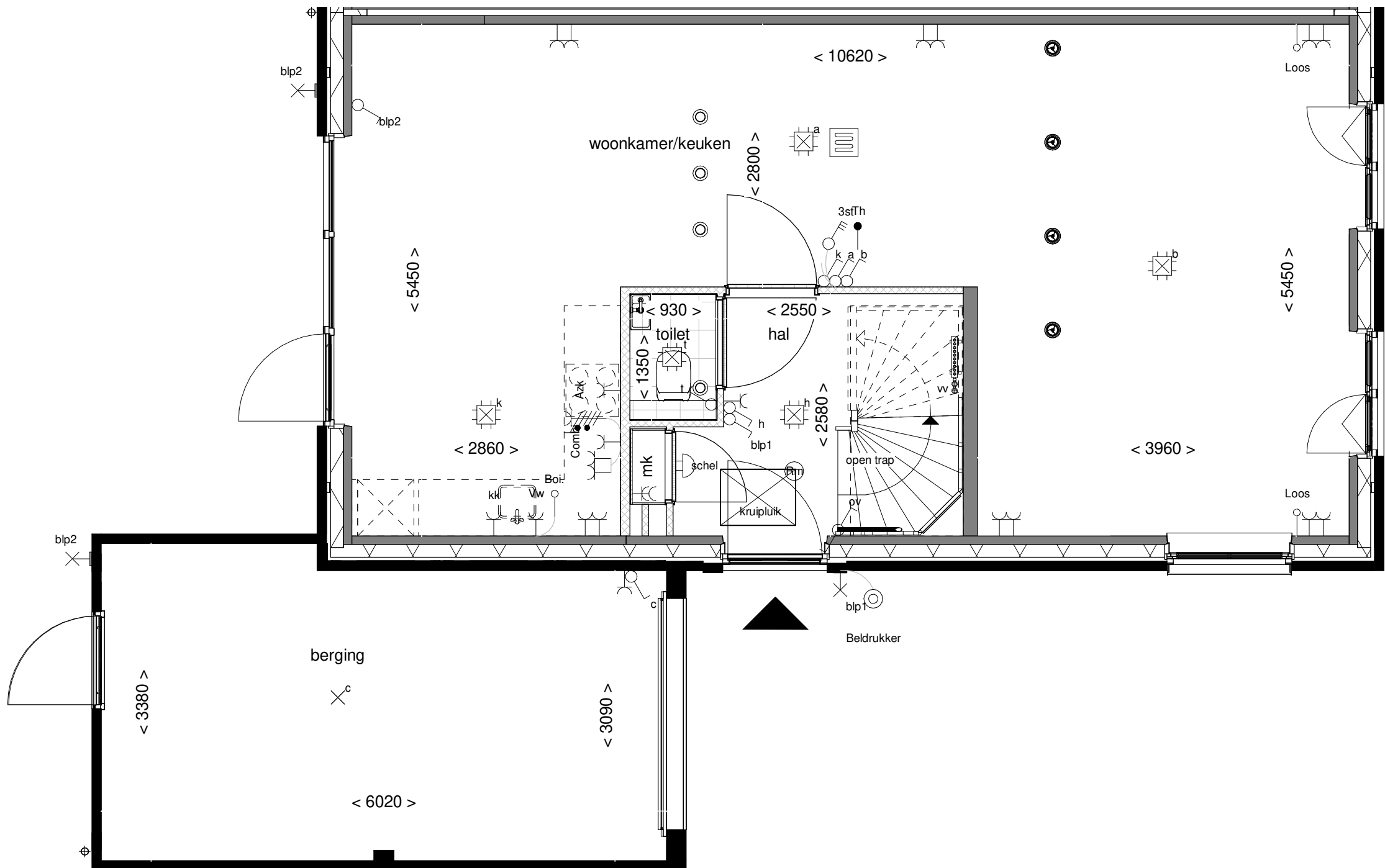

Tekening: **Begane grond**

Woningtype: **E57**

Bouwnummer: **403**

Bladnummer: **VT-E57-403a**

Bladformaat: **A3**

Schaal: **1:50**

Datum: **07-09-2023**

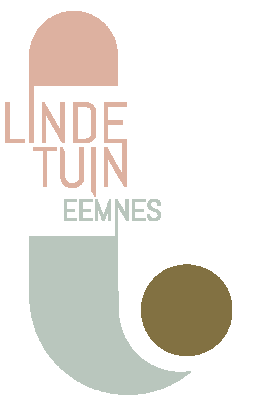
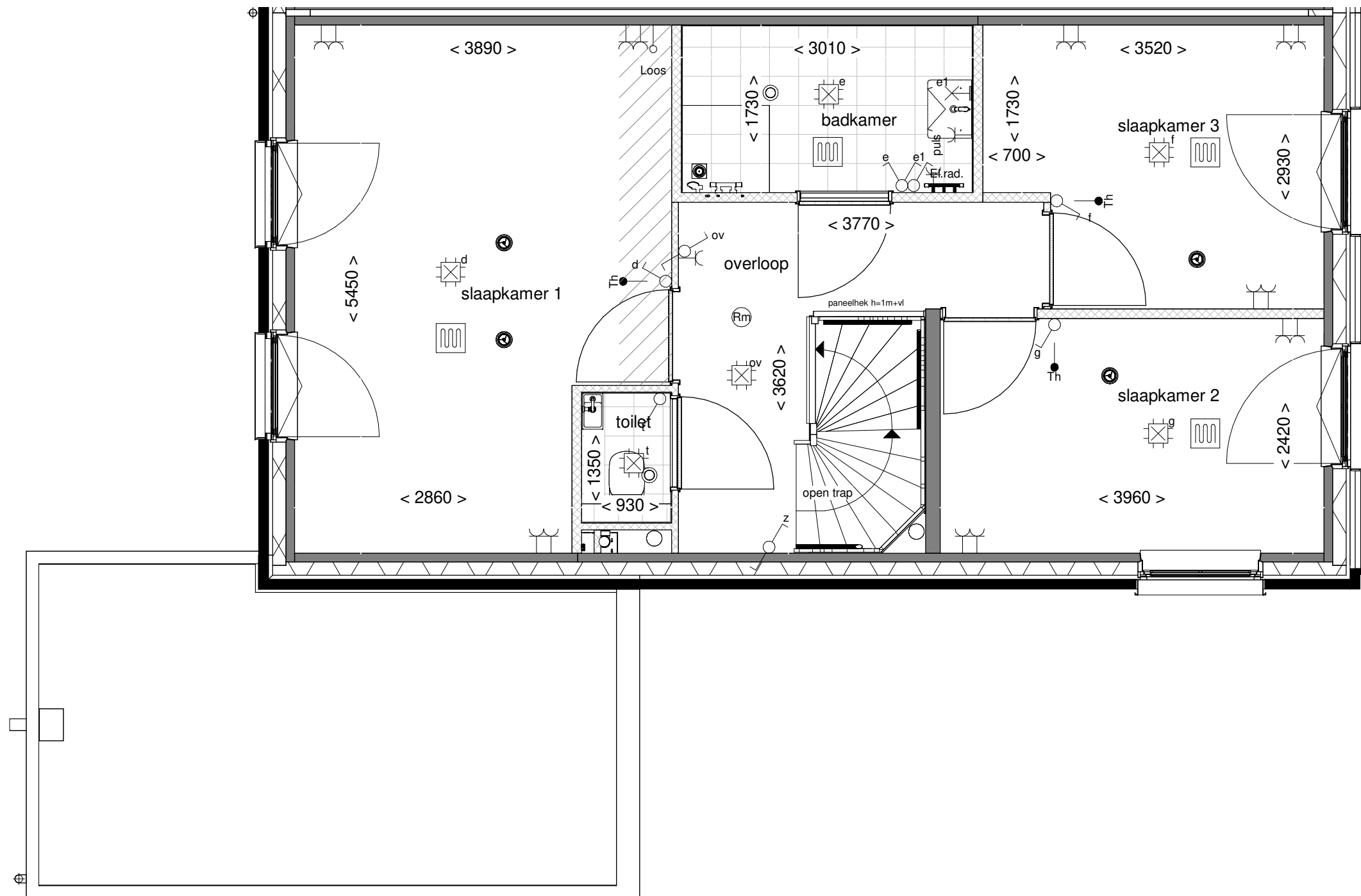

Tekening: **Eerste verdieping**

Woningtype: **E57**

Bouwnummer: **403**

Bladnummer: **VT-E57-403b**

Bladformaat: **A3**

Schaal: **1:50**

Datum: **07-09-2023**

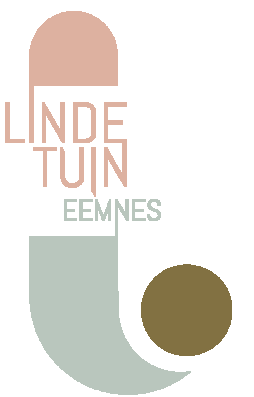
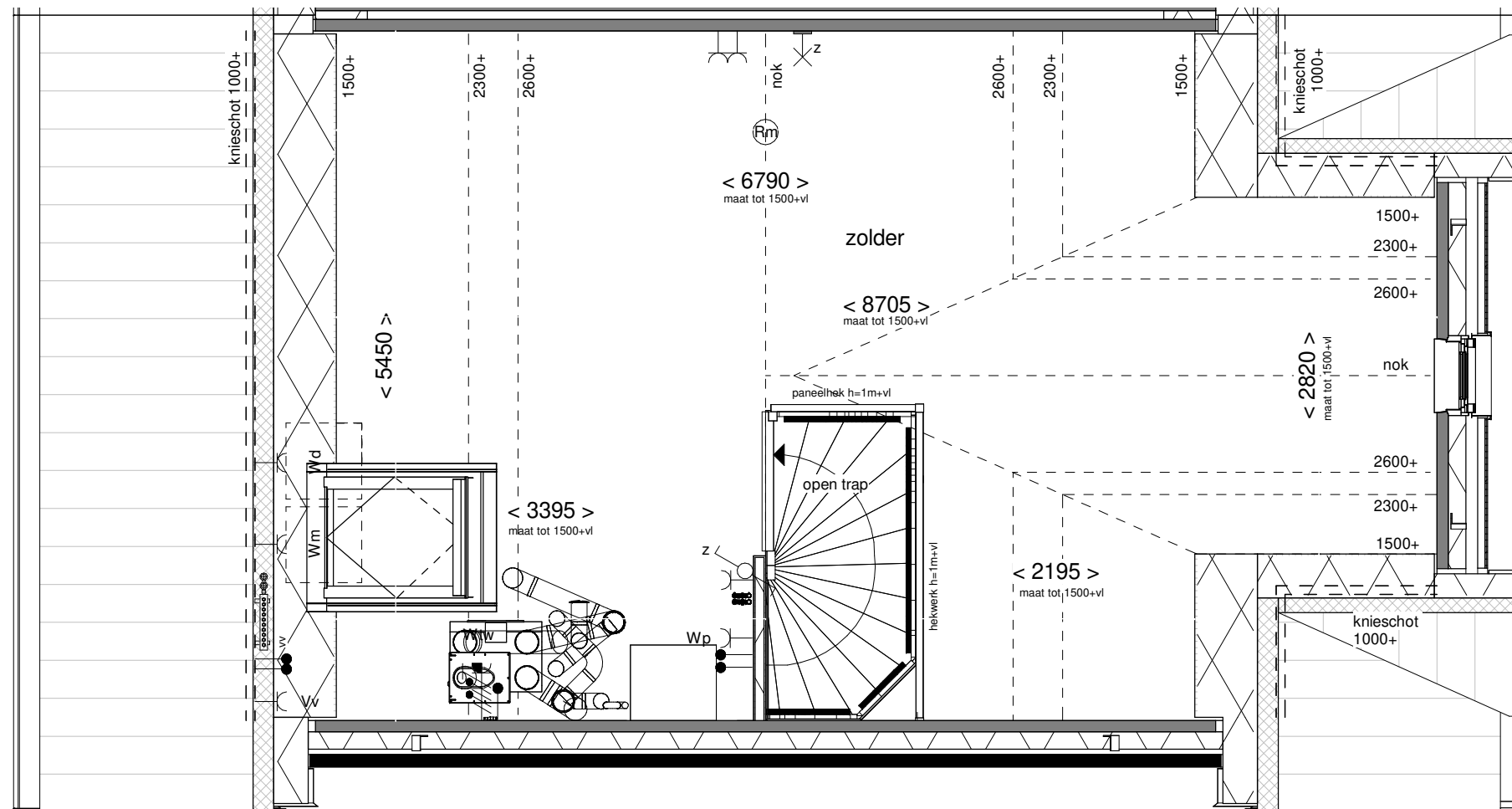

Tekening: Tweede verdieping

Woningtype: E57

Bouwnummer: 403

Bladnummer: VT-E57-403c

Bladformaat: A3

Schaal: 1:50

Datum: 07-09-2023

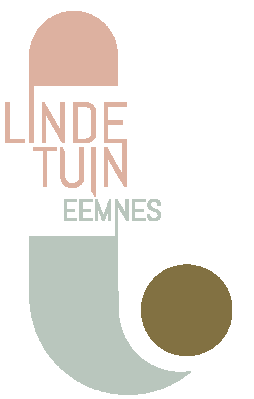
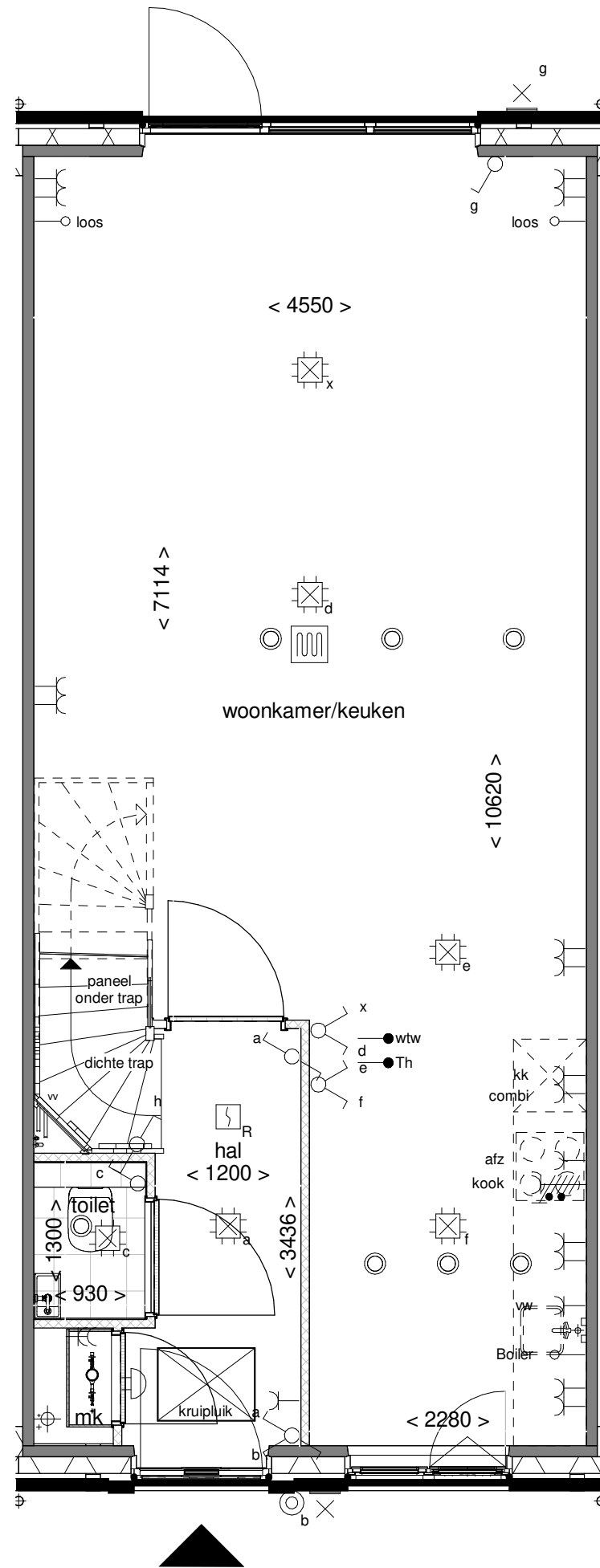

Tekening: **Begane grond**

Woningtype: **B48+**

Bouwnummer: **404**

Bladnummer: **VT-B48+-404a**

Bladformaat: **A3**

Schaal: **1:50**

Datum: **07-09-2023**

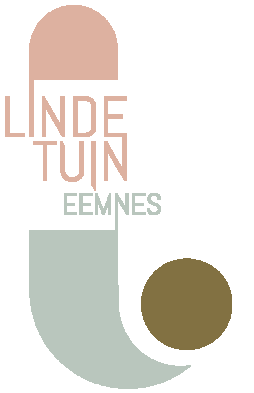
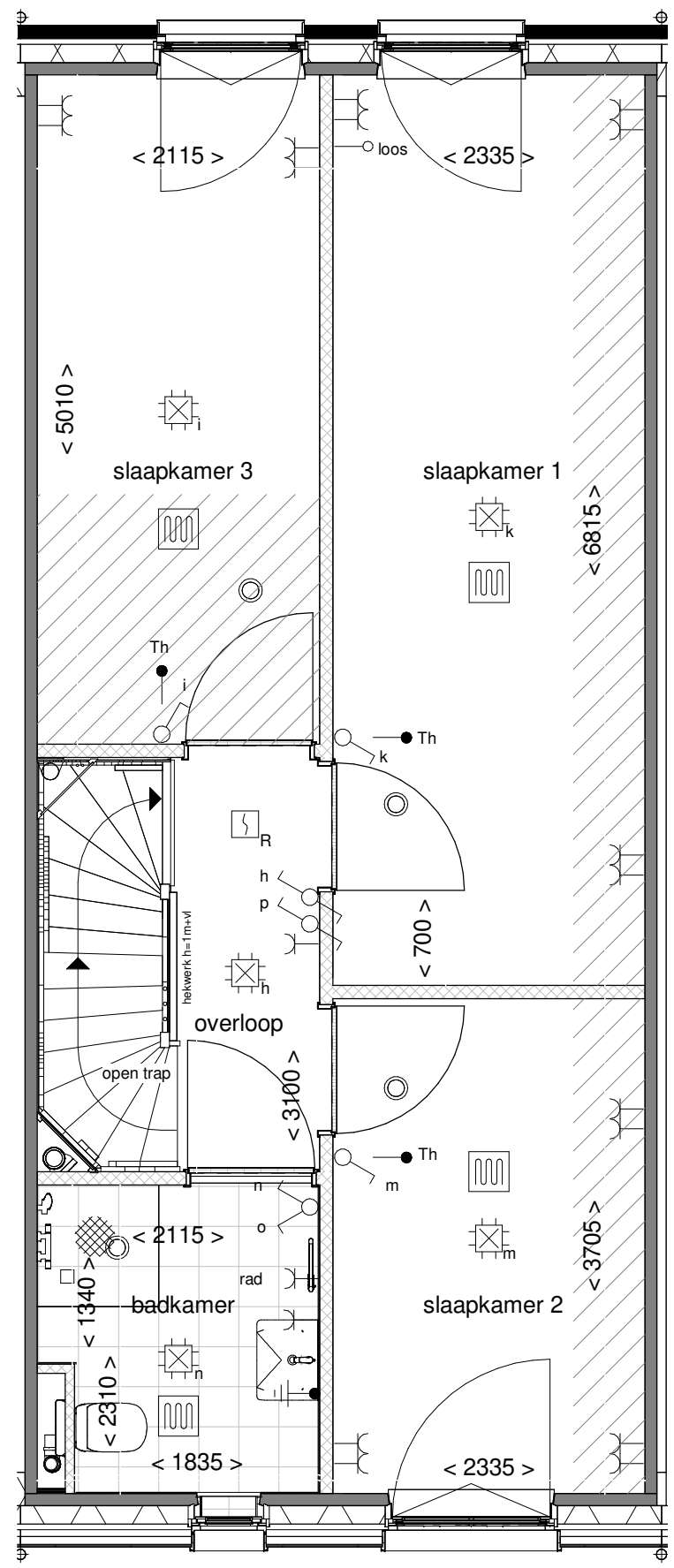

Tekening: **Eerste verdieping**

Woningtype: **B48+**

Bouwnummer: **404**

Bladnummer: **VT-B48+-404b**

Bladformaat: **A3**

Schaal: **1:50**

Datum: **07-09-2023**

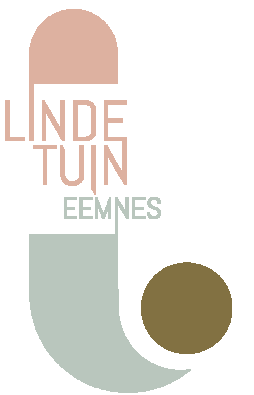
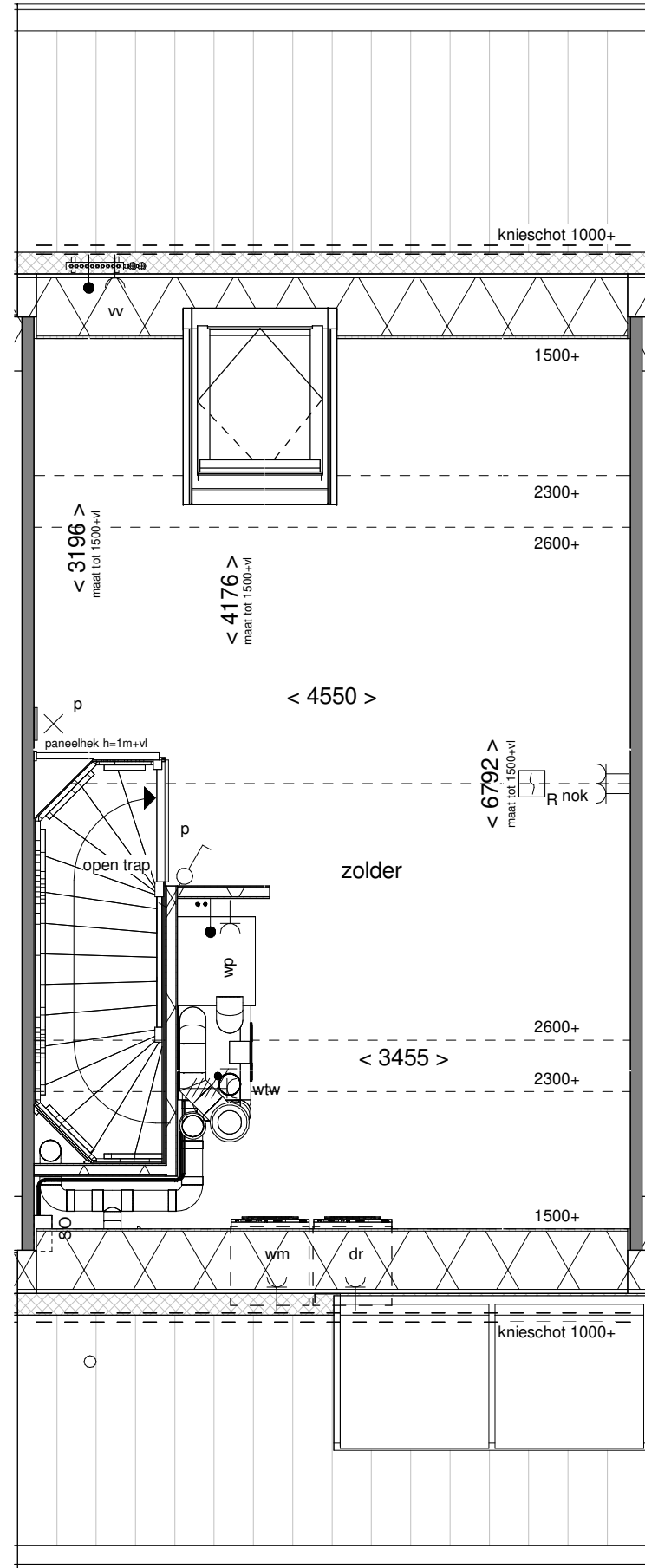

Tekening: **Tweede verdieping**

Woningtype: **B48+**

Bouwnummer: **404**

Bladnummer: **VT-B48+-404c**

Bladformaat: **A3**

Schaal: **1:50**

Datum: **07-09-2023**

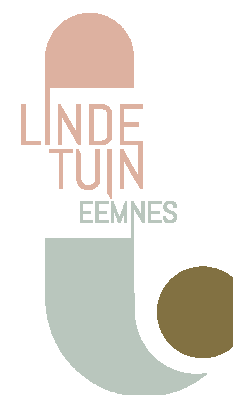
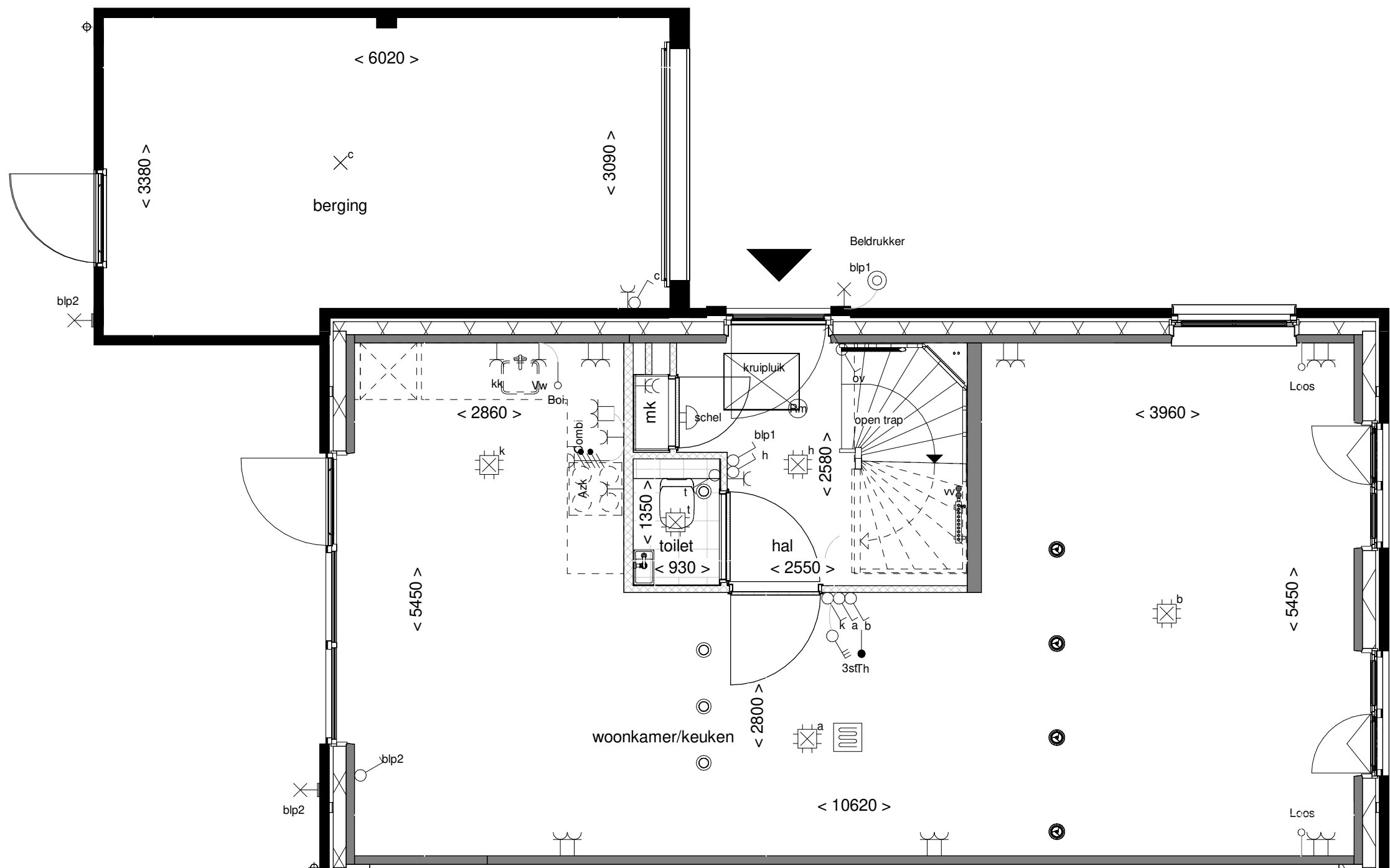

Tekening: **Begane grond**

Woningtype: **E57**

Bouwnummer: **405**

Bladnummer: **VT-E57-405a**

Bladformaat: **A3**

Schaal: **1:50**

Datum: **07-09-2023**

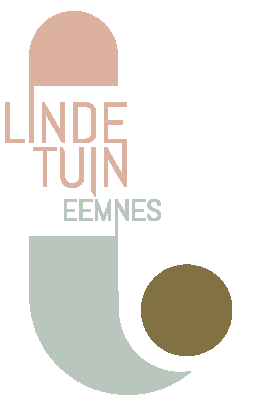
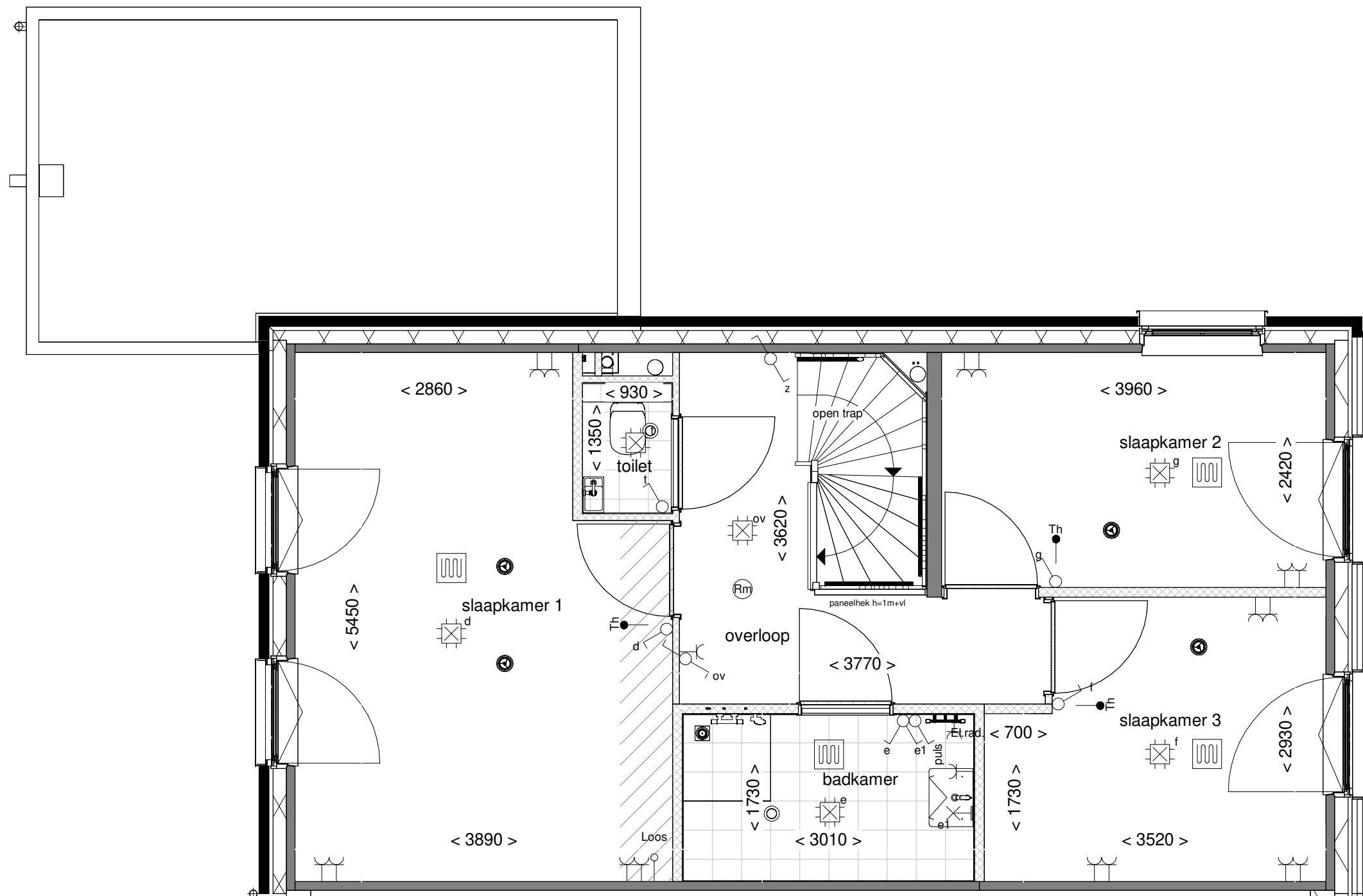

Tekening: **Eerste verdieping**

Woningtype: **E57**

Bouwnummer: **405**

Bladnummer: **VT-E57-405b**

Bladformaat: **A3**

Schaal: **1:50**

Datum: **07-09-2023**

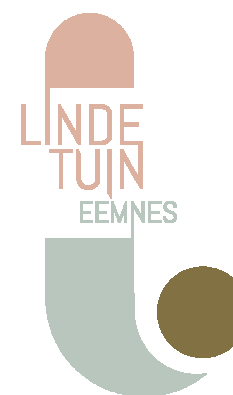
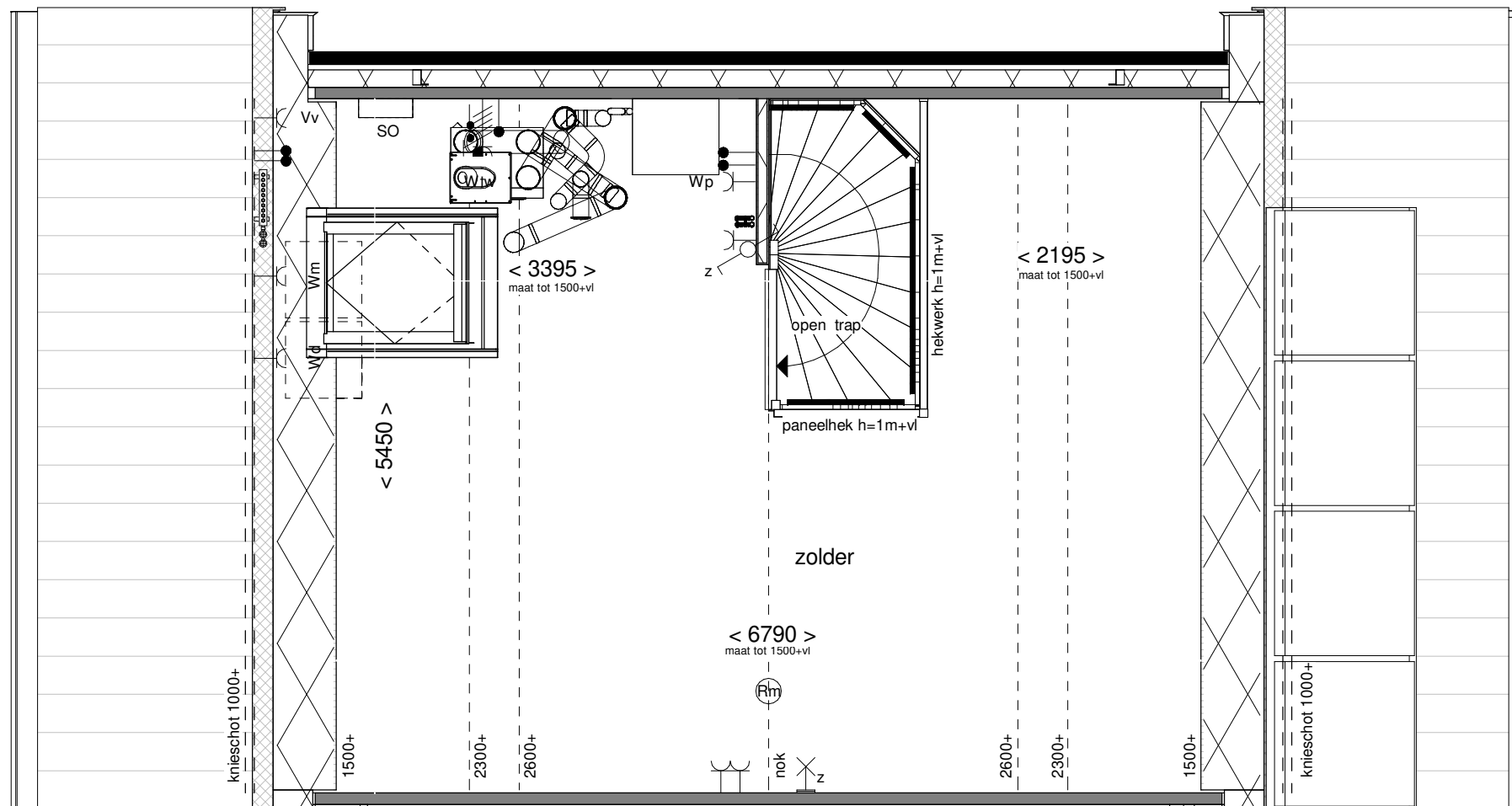

Tekening: Tweede verdieping

Woningtype: E57

Bouwnummer: 405

Bladnummer: VT-E57-405c

Bladformaat: A3

Schaal: 1:50

Datum: 07-09-2023

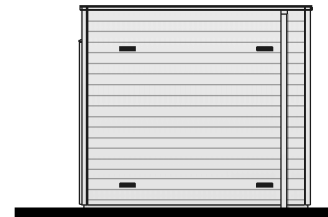

Voorgevel

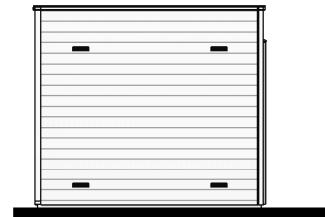

Achtergevel

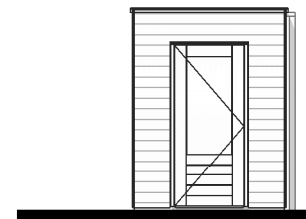

Linker zijgevel

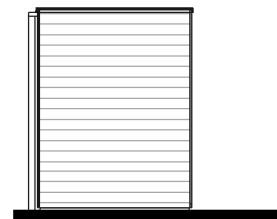

Rechter zijgevel

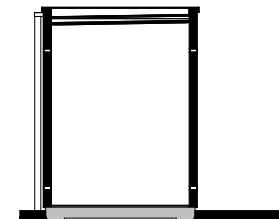

Doorsnede A

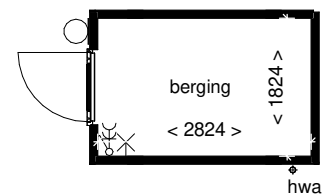

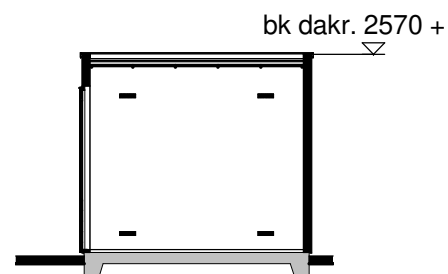

Begane grond







Doorsnede B

Renvooi

-  houten rabatdelen
-  houten wanden

Installaties

-  - enkelpolige schakelaar
-  - dubbele wandcontactdoos
-  - lichtpunt buiten
-  - lichtpunt aan wand

Disclaimer

De op deze tekening aangegeven maten zijn circa maten in millimeters en tussen de wanden / vloeren gemeten, waarbij geen rekening is gehouden met enige wandafwerking, plinten, aftimmering, ect. In verband met de nauwkeurige uitwerking van details, constructie, maatvoering, materialen e.d. kunnen er kleine afwijkingen ontstaan ten opzichte van de nu vermelde gegevens. Deze geringe afwijkingen geven geen aanleiding tot verrekening. Aan de op deze tekening aangegeven maten kunnen derhalve geen rechten worden ontleend. De op deze tekening aangegeven maatvoering is niet geschikt voor opdrachten aan derden door koper(s). De posities van aansluitingen en installatie onderdelen zijn indicatief op tekening aangegeven. De exacte aantallen en posities zullen na berekening in het werk door de installateurs worden bepaald en kunnen afwijken van deze tekening.

3D Impressie

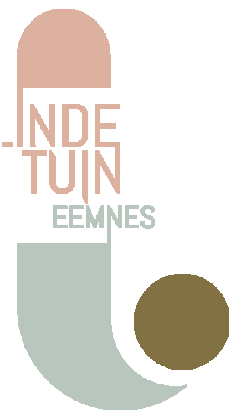
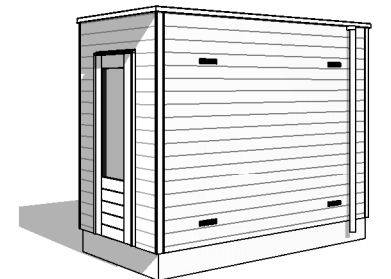

Tekening: **Berging enkel**

Woningtype: -

Bouwnummer: -

Bladnummer: VT-00-B1

Bladformaat: A3

Schaal: 1:100

Datum: 07-09-2023

Van toepassing bij bouwnummer: 394

Gespiegeld bij bouwnummer: 382, 385, 387, 401 en 404